



ISO Registered Company



MODEL 1000HP

PROCESS PRESSURE REDUCING REGULATOR

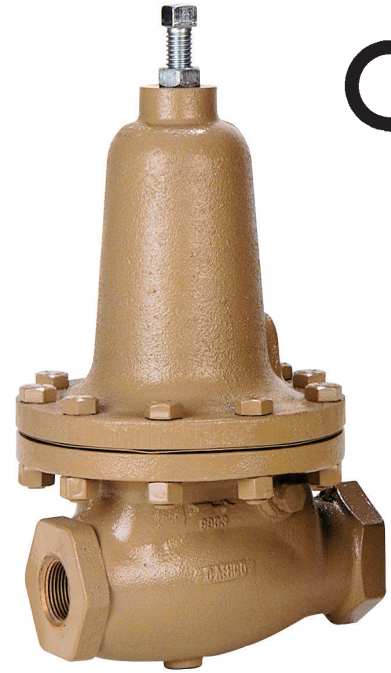

MODEL 1000HP

OVERVIEW

The Model 1000HP is a high capacity, high pressure regulator used to control downstream pressure between 10 and 300 psig (0.69 and 20.7 Barg). Available in sizes from 1/2" through 2" (DN15 through DN50). The unique internal design allows use in a multitude of applications, including process fluids that normal pressure reducing regulators can not match. The most versatile self-contained, pressure reducing regulator available to users.

FEATURES

- Streamlined Flow Path:** Straight-through flow path reduces internal turbulence and resistance to flow, increasing stability and capacity.
- High Inlet Pressures:** Standard construction allows inlet pressures up to 740 psig (51.0 Barg).
- High Outlet Pressures:** Controlled outlet pressure up to 300 psig (20.7 Barg).
- High Pressure Drop:** Standard construction with extended guiding allows pressure drop up to 650 psid (44.8 Bard). This regulator is routinely applied in severe service conditions.
- Flow-to-Open Plug:** Provides unmatched rangeability – far greater than competitive flow-to-close designs. Highly stable at either high or low flow rates.
- Versatility:** Four body materials and nineteen trim material selections allow usage in a multitude of various fluids. Optional constructions extend the capability.
- Protected Diaphragm Zone:** Internal arrangement isolates the diaphragm from direct impingement, negating any flow induced instability at either low or high flow rates. Allows incorporation of dynamic boost from jet section. Uniformly registers pressure on the diaphragm.
- Diaphragm Travel Stops:** Incorporates mechanical stop in spring chamber to limit diaphragm uptravel and in body for downtravel, minimizing potential internal damage from over-travel conditions.

* Refer to technical bulletin 1000HP-DIFF-TB for differential pressure applications. Refer to technical bulletin 1000HP-CRYO-TB for cryogenic reducer applications.

* Refer to technical bulletins 1000LP-BASIC-TB for the low pressure (LP) variation of the Model 1000 products. Refer to technical bulletin 1000HP-SF for the high inlet pressure variation.



LINE SIZES AVAILABLE

1/2" (DN15), 3/4" (DN20), 1" (DN25), 1-1/4" (DN32), 1-1/2" (DN40), AND 2" (DN50)



END CONNECTIONS

NPT, FLANGED, BSPT, BSP, EXTENDED NIPPLES, 14" FACE TO FACE



COMMON APPLICATIONS

STEAM, INDUSTRIAL GASES, SOUR GASES, FUEL OILS, COMPRESSED AIR, CHEMICALS, WATER CONDENSATE



DESIGN PRESSURE

INLET: UP TO 740 psig (51 Barg)
OUTLET: UP TO 300 psig (20.7 Barg)

STANDARD/GENERAL SPECIFICATIONS

Body Sizes: 1/2", 3/4", 1", 1-1/4", 1-1/2" and 2" (DN15, 20, 25, 32, 40 and 50).

End Connections: Standard – NPT female.
 Opt-30: 150# or 300# RF flanged.
 Opt-31: BSPT Tapered Thread.
 Opt-31P: BSPP Parallel Thread.
 Opt-32: Extended plain end nipples.
 Opt-34: 14" Face to Face Flange Dim. (Sizes 1/2"- 1" & 1-1/2" only)

Body/Spring Chamber Material Combinations: Uniform – DI/DI, BRZ/BRZ, CS/CS and SST/SST.
 Combinations – CS/DI, BRZ/DI, SST/DI and SST/CS.

DI = Ductile iron
 CS = Cast carbon steel
 BRZ = Cast bronze
 SST = Cast stainless steel

See Table 5 for material specifications.
NOTE: 1-1/4" (DN32) SST or BRZ bodies not available.

Trim Designs: Metal seated or composition seat (see Figure 1). Metal or composition diaphragms.

"B_" series designations – BRZ, BR, SST; see Table 7 for materials.
 "S_" series designations – SST; See Table 8 for materials.

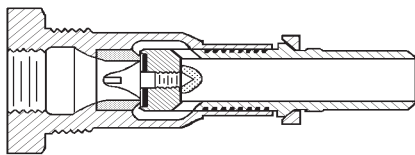

Figure 1: Composition Seat Design

Body/Cylinder Material Combinations: DI/BRZ, DI/SST.
 BRZ/BRZ.
 CS/SST, SST/SST.

Maximum Inlet Pressure: Dependent only on cylinder material and type of end connection (See Table 16):

BRZ – 400 psig (27.6 Barg);
 SST – 740 psig (51.0 Barg);

NOTES: 1. 1000HP is a flow-to-open (FTO) design; this places an upper limitation on inlet pressure for a given outlet pressure setting.
 2. Pressure/temperature ratings are reduced for Opt-37 and -37S due to use of SST bolting.

Temperature Range:

Standard: For body/cylinder/spring chamber construction with:
any BRZ materials –
 -20° to +400°F (-29° to +205°C).
DI, CS (WCB) or SST materials –
 -20° to +450°F (-29° to +232°C)

Optional: For body/cylinder/spring chamber construction with Opt-46G carbon graphite gasket:
CS (WCB) or SST materials –
 -20° to +600°F (-29° to +315°C)

NOTE: Composition trim materials may lower above ranges.

Outlet Pressure Range:

See Table 2 for individual range spring span.

Body Size		Full Range		Number of Range Springs
in	(DN)	psig	(Barg)	
1/2"	(15)	10 - 300	(0.7-20.7)	5
3/4"	(20)			6
1"	(25)	10 - 225	(0.7-15.5)	6
1-1/4"	(32)			5
1-1/2"	(40)	10 - 150	(0.7-10.3)	4
2"	(50)			3

NOTES: 1. 1000HP is a flow-to-open (FTO) design; this places a lower limitation on outlet pressure setting for some inlet pressure levels.
 2. Opt-37 and -37S use SST range springs, reducing number of range spring choices available.

Maximum Pressure Drop:

Metal Seat Designs:
 "B_" series trim designations – up to 390 psid (26.9 Bard).
 "S_" series trim designations – up to 650 psid (44.8 Bard).

Composition Seat Designs:
 "B_" series trim designations – up to 390 psid (26.9 Bard).
 "S_" series trim designations – up to 650 psid (44.8 Bard).

Minimum Pressure Drop: Standard: $\Delta P > 5$ psid (0.34 Bard)
Opt-17: $\Delta P \leq 1-5$ psid (0.07-0.34 Bard)
 Minimum = 1 psid (0.07 Bard).

Seat Leakage: Meets ANSI/FCI 70-2.
Metal Seated – Class IV.
Composition Seat – Class VI.

See Tables 9 through 12 for flow capacity expressed in Cv's for full port and 1-step reduced port (Opt-12).

See Table 3 for "Wide Open Cv"; use for sizing of safety relief device.

Range Springs Standard: Heat treated steel, zinc plated.
Opt-37 and -37S: SST.

Diaphragm Flange Bolting: Standard: High strength, zinc plated, heat treated steel.
Opt-37 and -37S: SST.

Gaskets: Required for metal diaphragm constructions only; not required for composition diaphragm construction.
Standard: Graphite/NBR.
(Not suitable for oxygen service.)
 $T_{max} = 450^{\circ}F$ (232°C)
Opt-45: Alternate TFE gaskets primarily for oxygen service.
 $T_{max} = 400^{\circ}F$ (205°C).
Opt-46G: Alternate carbon graphite gaskets.
 $T_{max} = 600^{\circ}F$ (315°C).

Painting: Standard All non-corrosion resistant portions to be painted with corrosion resistant epoxy paint per Cashco Spec #S-1606.

OPTION SPECIFICATIONS

Option -1: CLOSING CAP. A removable ductile iron cap discourages tampering with spring setting. Available only with DI or CS spring chamber materials. Includes a gasket for sealing the closing cap to the spring chamber, a sealing lock nut and a 1/4" NPT female vent connection.

Option -1+6: DIFFERENTIAL CONSTRUCTION.
Option -1+8: Refer to Technical Bulletin 1000HP-DIFF-TB for technical information for differential pressure applications.

Option -3: MANUAL ADJUSTOR AND LOCKING LEVER. Use when frequent spring range settings are required. For sizes 1/2", 3/4" and 1" (DN15, 20 and 25) adjusting screw has handwheel fixed to end, and locking nut is replaced by a locking lever that is easily loosened/tightened. For sizes 1-1/4", 1-1/2" and 2" (DN32, 40, 50) handwheel is replaced by T-bar adjustor.

Option -5: BRZ/BR CRYOGENIC CONSTRUCTION. Refer to Technical Bulletin 1000HP-CRYO-TB for technical information for cryogenic applications.

Option -12: REDUCED PORT ORIFICE. Used when high inlet pressure negates use of the standard full port orifice. Also used when oversized piping is desired to accommodate piping size. Available in metal seated or composition seat materials, in all "B_" or "S_" series trim designations, and in all body sizes except 1-1/4" (DN32). See Tables 10 and 12 for flow capacity in Cv's.

Option -14: INTEGRAL SEAT. Standard pressed-in seat ring-to-cylinder joint is sealed as a path of leakage by brazing or welding. The procedure also serves as a permanent joint for flow conditions where service conditions are "severe", subject to vibration, or thermal cycling.

Seat ring is silver brazed to cylinder for all "B_" series **composition** trim designations, and to 1/2" (DN15) body size cylinders with "S_" series trim designations. For all other body sizes with "S_" series designations the seat ring is welded to the cylinder.

OPTION SPECIFICATIONS

Recommended for all hydrogen or helium applications. Recommended when pressure drop exceeds 300 psid (20.7 Bard). Required when pressure drop exceeds 450 psid (31.0 Bard).

NOTE: Opt-14 is now included whenever Opt-15, stellite seat surfaces is specified.

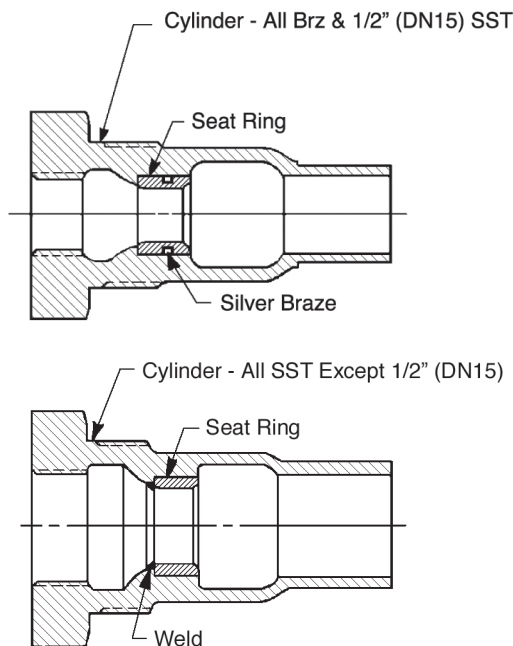

Figure 2:

Opt-14 Integral Seat

Option -15:

STELLITED SEAT SURFACES. Available with metal seated S1 trim only, and with full port orifice or Opt-12 reduced port orifice. Both plug face and seat ring's seat edge are coated with stellite hard surfacing using a flame spray process. Includes integral seat ring Opt-14.

Required for applications when:

1. Liquid flow is flashing and when both outlet pressure $P_2 < 50$ psig (3.5 Barg) and $\Delta P > 50$ psid (3.5 Bard).
2. Steam service when inlet pressure $P_1 > 450$ psig (31.0 Barg).
3. Steam service when $\Delta P > 300$ psid (20.7 Bard).
4. 2-phase flow (liquid + vapor i.e. "wet" steam) at inlet.

Option -17:

PISTON SPRING. Required for applications where pressure drop is less than 5 psid (0.34 Bard). Minimizes plug/cylinder frictional effects. 302 SST material only. Standard with B5 trim. Not available in 2" (DN50) body size with CS cylinder.

Option -20:

PRESSURE LOADED. Former Opt-20 with dome loaded topworks is obsolete. Use 1000HP-1+6 as alternate. See technical bulletin 1000HP-DIFF-TB.

Option -25:

REMOTE VENTING. Use with hazardous or explosive gases where personnel/equipment safety is at issue when a diaphragm leak occurs. 1/4" NPT female connection in spring chamber for piping.

Option -25P:

PLASTIC RAIN PROOF BUG VENT. (For Opt-25).

Option -25S:

SST RAIN PROOF BUG VENT. (For Opt-25).

Option -26:

DRAIN HOLE. 1/4" NPT drain tap with plug in body underside. Recommend use with highly viscous fluids (above 100 centipoise (Cp)) for downstream piping pressure sensing. Plug material similar to body material. Recommended for flashing liquids.

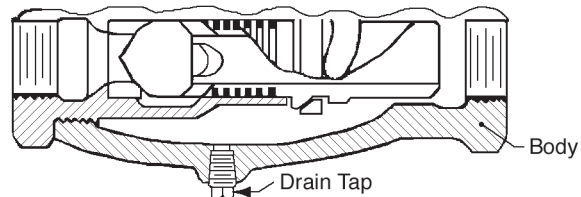

Figure 3:

Opt-26 Drain Hole

Option -27:

VISCOUS LIQUID SERVICE. Incorporates special valve plug with drilled openings near the "jet effect" zone to stabilize operation for fluids with viscosity greater than 100 Cp. Brass or SST metal seated trim ONLY.

Option -30:

FLANGED END CONNECTIONS. CS or SST body materials only. Flange and pipe nipple materials of same general chemistry as body material. Available as 150# RF or 300# RF flange configurations. Pressure \ Temperature ratings for Carbon Steel body per ASME B16.5. Group 1.1 and ASME B16.5 for SST body. Requires lapped joint-type flange on inlet (cylinder) end. Pipe nipples socket welded to body and cylinder. Outlet connection flange is socket

weld-type. See Table 16 for lowered P vs T ratings. No post-weld stress relieving performed. Not available in 1-1/4" (DN32) body size. (Suitable for NACE service with post-weld, stress relief, heat treatment).

Option -31 BSPT END CONNECTIONS. British Standard Tapered Pipe threads per ISO 7/1; used as alternate to NPT.

Option -31P: BSPP END CONNECTIONS. British Standard Parallel Pipe threads per ISO 7/1; used as alternate to NPT ends.

Option -32: EXTENDED P.E. NIPPLES. Schedule 80 plain end pipe nipples used for field butt or socket welding into pipeline. Pipe nipples of same general chemistry as body material. Short-threaded pipe nipples seal welded to body and cylinder. Adds approximately 8 inches (200 mm) to the face-to-face dimension of standard unit. Use for socket weld pipe systems. (Suitable for NACE service with post-weld, stress relief, heat treatment).

Option -34: SPECIAL 14" FACE TO FACE DIMENSION FOR FLANGED END CONNECTIONS. Sizes 1/2" - 1" & 1-1/2" only. See Opt.-30 for standard face to face dimension.

Option -36: SST CRYOGENIC CONSTRUCTION. Refer to technical bulletin 1000HP-CRYO-TB for technical information for cryogenic applications.

Option -37: ALL SST/CLEAN UNIT FOR LIQUIDS AND GASES. Packaged primarily for the food and pharmaceutical industries. NPT and 150# SST RF flanged end connections ONLY. 316 SST body and spring chamber materials ONLY. Use with S6 trim ONLY. T-bar handle, spring chamber internals, and flange bolting of SST materials. All wetted and external castings are electropolished, and the unit is cleaned to Cashco Spec. #S-1576. Includes Opt-26 1/4" NPT tap with SST plug.

Use of SST diaphragm flange bolting limits P vs T ratings to levels below standard unit (see Table 16). Also limits pressure settings to overall range of 10–80 psig (0.7–5.5 Barg) using multiple SST springs.

Option -37S: ALL SST/CLEAN UNIT FOR STEAM. Similar to Option -37, except is equipped with different trim; use with S1 trim ONLY. Includes carbon graphite diaphragm gasket material. Includes Opt-26 1/4" NPT tap with SST plug. Use of SST flange bolting limits P vs T ratings to levels below standard unit (see Table 16). Also limits pressure settings to overall range of 10–80 psig (0.7–5.5 Barg) using multiple SST springs.

Option -40: NACE CONSTRUCTION. Internal wetted portions meet NACE standard MR0175 for application in sour gas service. Exterior of the unit to not be directly exposed to a sour gas environment, buried, insulated or otherwise denied direct atmospheric exposure. CS/CS or SST/CS body/spring chamber materials ONLY. Acceptable ONLY with S40, S40V, S3, or S3N trims. Not available with Opt-14, Opt-15, Opt-17, or Opt-37.

Option -45: TFE/SILICATE-GASKET. Primarily for oxygen service. Limits temperature range to -20° to +400°F (-29° to +205°C). Not required when using a composition diaphragm.

Option -46G: HIGH TEMPERATURE GASKETS. CS (WCB) or SST body/spring chamber materials only with S1 or S2 trim. Utilizes carbon graphite gaskets over standard gaskets. Primarily applied at temperatures over 400°F (205°C) or at customer's request; range of -20° to +600°F (-29° to +315°C). (See Table 8 a.1)

Option -55: SPECIAL CLEANING. BRZ or SST body materials ONLY. Cleaning per Cashco Spec #S-1134 for Oxygen gas Service. **NOTE:** Design Pressure Rating shall not exceed 375 psig (25.8 Barg) when body material is SST and process medium is oxygen.

Option -56: SPECIAL CLEANING. Cleaning per Cashco Spec #S-1542. **NOT suitable for Oxygen Service.**

Option -87: TWO 1/8" (DN6) NPT TAPS. One located on the inlet, one on the outlet for gauge connections for Opt-34 only.

TECHNICAL SPECIFICATIONS

**TABLE 1
RECOMMENDED PRESSURE DROP VS. TRIM DESIGN/MATERIALS**

NOTE: Consult Factory with Application Details For ΔP 's > 450 psid (31 Bard).

NOTE: Cashco, Inc. does not recommend metal seated trim on any service where the flow will be dead ended down stream of the pressure reducing regulator.

Fluid	Maximum Inlet Pressure		Operating Pressure Drop Range		Seat Design	Basic Trim Materials	Trim Designation Numbers
	psig	(Barg)	psid	(Barg)			
Liquids (Noncavitating)	400	(27.6)	5 - 250	(0.34 - 17.2)	Soft Seat - All Comp Materials	BRZ/BR	BB, B2, B3, B5, BK
	740	(51.0)	5 - 400	(0.34 - 27.6)	Soft Seat - All Comp Materials	SST	S3, S3N, S6, S7, S9, SB, S40V, S36
	400	(27.6)	5 - 390	(0.34 - 26.9)	Metal Seated	BRZ/BR/SST	B1
	740	(51.0)	5 - 650	(0.34 - 44.8)	Metal Seated	SST	S2, S2N, S0, S1, S5, S40
Gas	400	(27.6)	5 - 390	(0.34 - 26.9)	Soft Seat - All Comp Materials except SST/TFE	BRZ/BR	BB, B2, B3, B5, BK
						SST	S6, S3N, SB, S40V
	740	(51.0)	5 - 650	(0.34 - 44.8)	Soft Seat - SST/TFE ONLY	SST	S3, S9, S36
					Metal Seated	SST	S2, S2N, S0, S1, S5, S40
Steam	400*	(27.6)	5 - 200*	(0.34 - 13.8)	Metal Seated	BRZ/BR/SST	B1
	450	(31.0)	5 - 300	(0.34 - 20.7)	Metal Seated	SST	S1, S2
	740	(51.0)	5 - 650	(0.34 - 44.8)	Metal Seated - Opt-15 Stellite	SST	S1

* Saturated Only **NOTE:** For ΔP = 1-5 psid (.07 - .34 Bard), use Opt-17 piston spring.

TABLE 2
RANGE SPRINGS

Body Size		Standard - Steel		SST - Opts. -37 & 37S	
in.	(DN)	psig	(Barg)	psig	(Barg)
1/2"	(15)	10-50	(.7-3.4)	10-50	(.7-3.4)
		40-100	(2.7-6.9)	40-80	(2.7-5.5)
		80-150	(5.5-10.3)	N/A	N/A
		120-190	(8.3-13.1)		
		150-300	(10.3-20.7)		
3/4"	(20)	10-40	(.7-2.7)	10-40	(.7-2.7)
		30-60	(2.1-4.1)	30-60	(2.1-4.1)
		50-90	(3.4-6.2)	50-80	(3.4-5.5)
		70-110	(4.8-7.6)	N/A	N/A
		90-170	(6.2-11.7)		
		140-300	(9.6-20.7)		
1"	(25)	10-40	(.7-2.7)	10-30	(.7-2.1)
		30-60	(2.1-4.1)	25-45	(1.7-3.1)
		50-70	(3.4-4.8)	35-50	(2.4-3.4)
		55-80	(3.8-5.5)	40-80	(2.7-5.5)
		65-130	(4.5-8.9)	N/A	N/A
		100-300	(6.9-20.7)		
1 1/4"	(32)	10-40	(.7-2.7)	N/A	N/A
		30-50	(2.1-3.4)		
		40-60	(2.7-4.1)		
		50-90	(3.4-6.2)		
		70-225	(4.8-15.5)		
1-1/2"	(40)	10-40	(.7-2.7)	10-50	(.7-3.4)
		30-75	(2.1-5.2)	40-80	(2.7-5.5)
		60-100	(4.1-6.9)	N/A	N/A
		80-225	(5.5-15.5)		
2"	(50)	10-40	(.7-2.7)	10-30	(.7-2.1)
		30-60	(2.1-4.1)	25-45	(1.7-3.1)
		50-150	(3.4-10.3)	35-80	(2.4-5.5)

TABLE 3
MAXIMUM CAPACITY – Cv
FOR SIZING SAFETY RELIEF DEVICE
(WITH PLUG WIDE OPEN)

Body Size		Orifice Size			
		Standard		Opt.-12 Reduced	
inch	(DN)	Size	Cv	Size	Cv
1/2"	(15)	1/2"	5	3/8"	3
3/4"	(20)	3/4"	9	1/2"	7
1"	(25)	7/8"	9	5/8"	8
1-1/4"	(32)	1"	13	NA ¹	NA ¹
1-1/2"	(40)	1-1/4"	17	7/8"	13
2"	(50)	1-1/2"	22	1-1/4"	20

NOTES: 1. NA = Not Available.
2. See Footnote 1 of Table 16 for technical information on safety relief valve or rupture disc setpoint pressure.

TABLE 4
MAXIMUM ALLOWABLE PRESSURE vs. TEMPERATURE;
FOR PRESSURE CONTAINMENT OF
BODY, SPRING CHAMBER AND CYLINDER
(See Table 5 for Material Specifications)

NOTE: The below ratings may be further "derated" by limitations through the Pressure Equipment Directive (2014/68/EU).

Materials of Construction ¹		Inlet - Cylinder				Outlet - Body & Spring Chamber			
		Pressure		Temperature		Pressure		Temperature	
		psig	(Barg)	°F	(°C)	psig	(Barg)	°F	(°C)
DI/DI/BRZ or BRZ/DI/BRZ	400	(27.6)	-20 to +150	(-29 to +66)	300	(20.7)	-20 to +300	(-29 to +149)	
	385	(26.5)	+200	(+94)	250	(17.2)	+400	(+205)	
	365	(25.2)	+250	(+121)					
	335	(23.1)	+300	(+149)					
	300	(20.7)	+350	(+177)					
	250	(17.2)	+400	(+205)					
BRZ/BRZ/BRZ	400	(27.6)	-20 to +150	(-29 to +66)	400	(27.6)	-20 to +150	(-29 to +66)	
	385	(26.5)	+200	(+94)	250	(17.2)	+400	(+205)	
	365	(25.2)	+250	(+121)					
	335	(23.1)	+300	(+149)					
	300	(20.7)	+350	(+177)					
	250	(17.2)	+400	(+205)					
DI/DI/SST or CS/DI/SST or SST/DI/SST	740	(51.0)	-20 to +450	(-29 to +232)	300	(20.7)	-20 to +300	(-29 to +149)	
					250	(17.2)	+450	(+232)	
CS/CS/SST or SST/CS/SST or SST/SST/SST	Standard Gasket or Option-45	740	(51.0)	-20 to +450 ²	(-29 to +232) ²	400	(27.6)	-20 to +450 ²	(-29 to +232) ²
CS/CS/SST or SST/CS/SST or SST/SST/SST	Option-46G	740	(51.0)	-20 to +600 ³	(-29 to +315) ³	400	(27.6)	-20 to +600 ³	(-29 to +315) ³

- 1 Pressure vs. temperature ratings in accordance with ASME B31.3.
- 2 Operating Temperature limit for Option-45 is 400F (+205C).
- 3 Requires use of Opt-46G, carbon graphite gasket for temperatures from +450 to +600°F (+232 to +315°C), S1 or S2 Trim only.

TABLE 5
MATERIAL SPECIFICATIONS OF
BODY, SPRING CHAMBER AND CYLINDER

Material	ASTM Specifications
BRZ - cast bronze	B62, Alloy 83600
DI - ductile iron	A395 Gr. 60-40-18
CS - cast carbon steel	A216, Gr. WCC (Body)
	A216, Gr. WCB (Spring Chamber)
SST - cast stainless steel	A351, Gr. CF8M (cast 316 SST)
	A479 UNS 31600/03

**TABLE 6
APPLICATIONS**

FLUID	Recommended Construction	Trim Designation No. ¹
Air or Inert Gases	Composition Seat & Diaphragm Metal Seat & Composition Diaphragm	BB, B2 , BK, B3, S3N, SB, S40V S2N
Liquids	Metal Seat & Diaphragm Composition Seat & Diaphragm	B1, S1 BB, B2 , B3, BK, S3N, SB, S40V
Chemicals	Metal Seat & Composition Diaphragm Metal Seat & Diaphragm Composition Seat & Diaphragm Composition Seat & Metal Diaphragm	S5, S40 S0 S3, S6, S40V S9, S36
Sour Gas/Crude	Metal Seat & Composition Diaphragm	S40
Sour Gas/Crude	Composition Seat & Diaphragm	S3, S40V, S3N
Fuel Oil	Composition Seat & Diaphragm	BB, SB
Hydrocarbon Gas or Liquids	Composition Seat & Diaphragm	BB, S3, S3N, S7, SB, S40V
Steam, Saturated or Superheated	Metal Seat & Diaphragm	S2 , B1, S1
Water and Condensate, Low Temperature (32° - 180°F) (0° - 83° C)	Composition Seat & Diaphragm Metal Seat & Composition Diaphragm	BB, B2 , B3, S3 , S3N, SB S2N
Water and Condensate High Temperature (180° - 300°) (83° - 149°C)	Metal Seat & Diaphragm	S1 , B1, or S2

¹ S1 trim is available with stellite faced plug and valve seat (Opt. -15)..

Note: Trim Designation Nos. in "boldface" are the most commonly used. Cashco, or its representatives, may make recommendations or suggestions as to the suitability of certain trims for specific services. These are trims that have been used successfully in the past in similar applications. However, the user has final responsibility for materials selected.

**TABLE 7
BRASS TRIM MATERIAL COMBINATIONS**

Part	Brass Trim#					
	B1	B2	B3	B5	BB	BK
Diaphragm	302 SST	BC	BC	Phos. BRZ	NBR	FKM
Cylinder	Brass	Brass	Brass	Brass	Brass	Brass
Valve Seat	316 SST	Brass	Brass	Brass	Brass	Brass
Plug	416 SST	Brass	Brass	Brass	Brass	Brass
Seat Disc	None (metal)	NBR	V-TFE	V-TFE	NBR	FKM
Seat Disc Screw	None	Brass	Brass	Brass	Brass	Brass
Plug Collar	Brass	Brass	Brass	Brass	Brass	Brass
Rocker Arm Shaft	Brass	Brass	Brass	Brass	Brass	Brass
Rocker Arm	CF8M	CF8M	CF8M	CF8M	CF8M	CF8M
Pusher Plate Stud	Brass	Brass	Brass	Brass	Brass	Brass
Pusher Plate	Bronze	Bronze	Bronze	Bronze	Bronze	Bronze
Stud Collar	Brass	Brass	Brass	Brass	Brass	Brass
Cotter Pin	Brass	Brass	Brass	Brass	Brass	Brass
Nut	Brass	Brass	Brass	Brass	Brass	Brass
Temperature Range °F	-20 to +400	-20 to +200	-20 to +200	-20 to +200	-20 to +250	-20 to +400
Temperature Range °C	-29 to +205	-29 to +93	-29 to +93	-29 to +93	-29 to +121	-29 to +205

NOTE: Cashco, Inc. does not recommend metal seated trim on any service where the flow will be dead ended down stream of the pressure reducing regulator.

TABLE 8 a

STAINLESS STEEL TRIM MATERIAL COMBINATIONS

Part	Metal Seat					
	S0	S1 ¹	S2	S2N	S5	S40 *
Diaphragm	TFE Coated 302 SST	302 SST	302 SST	BC	FKM	BC
Cylinder	CF8M	CF8M	CF8M	CF8M	CF8M	CF8M
Valve Seat	316 SST	316 SST	316 SST	316 SST	316 SST	316 SST
Plug	316 SST	316 SST	416 SST	416 SST	416 SST	316 SST
Seat Disc	None (Metal)	None (Metal)	None (Metal)	None (Metal)	None (Metal)	None (Metal)
Set Disc Screw	None	None	None	None	None	None
Plug Collar	316 SST	316 SST	316 SST	316 SST	316 SST	316 SST
Rocker Arm Shaft	316 SST	316 SST	316 SST	316 SST	316 SST	316 SST
Rocker Arm	CF8M	CF8M	CF8M	CF8M	CF8M	CF8M
Pusher Plate and Stud	CF8M	CF8M	CF8M	CF8M	CF8M	CF8M
Stud Collar	316 SST	316 SST	316 SST	316 SST	316 SST	316 SST
Cotter Pin	316 SST	316 SST	316 SST	316 SST	316 SST	316 SST
Nut	316 SST	316 SST	316 SST	316 SST	316 SST	316 SST
Temperature Range °F	-20 to 400	See Side Table 8 a.1		-20 to 200	-20 to 400	-20 to 200
Temperature Range °C	-29 to 205			-29 to 93	-29 to 205	-29 to 93

Gasket	Temp. Range
Standard	-20 to +450 (-29 to +232)
Option-45	-20 to +400 (-29 to + 205)
Option-46G	-20 to +600F (-29 to +315)

¹ Available with Stellite faced plug and valve seat (Opt. -15). Includes a screwed-in seat cone.

* Use for NACE service.

NOTE: Cashco, Inc. does not recommend metal seated trim on any service where the flow will be dead ended down stream of the pressure reducing regulator.

TABLE 8 b

STAINLESS STEEL TRIM MATERIAL COMBINATIONS

Part	Composition Seat							
	S3 *	S3N *	SB	S6	S7	S40V *	S9	S36
Diaphragm	BC	BC	NBR	EPDM	FKM	FKM	TFE Coated 302SST	302 SST
Cylinder	CF8M	CF8M	CF8M	CF8M	CF8M	CF8M	CF8M	CF8M
Valve Seat	316 SST	316 SST	316 SST	316 SST	316 SST	316 SST	316 SST	316 SST
Plug	316 SST	316 SST	316 SST	316 SST	316 SST	316 SST	316 SST	316 SST
Seat Disc	V-TFE	NBR	NBR	EPR	V-TFE	FKM	V-TFE	V-TFE
Set Disc Screw	316 SST	316 SST	316 SST	316 SST	316 SST	316 SST	316 SST	316 SST
Plug Collar	316 SST	316 SST	316 SST	316 SST	316 SST	316 SST	316 SST	316 SST
Rocker Arm Shaft	316 SST	316 SST	316 SST	316 SST	316 SST	316 SST	316 SST	316 SST
Rocker Arm	CF8M	CF8M	CF8M	CF8M	CF8M	CF8M	CF8M	CF8M
Pusher Plate and Stud	CF8M	CF8M	CF8M	CF8M	CF8M	CF8M	CF8M	CF8M
Stud Collar	316 SST	316 SST	316 SST	316 SST	316 SST	316 SST	316 SST	316 SST
Cotter Pin	316 SST	316 SST	316 SST	316 SST	316 SST	316 SST	316 SST	316 SST
Nut	316 SST	316 SST	316 SST	316 SST	316 SST	316 SST	316 SST	316 SST
Temperature Range °F	-20 to 200	-20 to +250	-20 to 300	-20 to 400				
Temperature Range °C	-29 to 93	-29 to +121	-29 to 149	-29 to 205				

NBR	= Buna-N
BC	= Neoprene
EPR	= Ethylene Propylene
EPDM	= Ethylene Propylene Diene
TFE	= Polytetrafluoroethylene
FKM	= Fluorocarbon elastomer
V-TFE	= Virgin TFE
Phos. BRZ	= Phosphor Bronze

* Use for NACE service.

TABLE 9
Cv – FLOW CAPACITY

FULL PORT – COMPOSITION DIAPHRAGM

Based on 400 psid (27.6 Bard) max pressure drop limit for composition seat,
and on 650 psid (44.8 Bard) for metal seat.

$(F_L = 0.93)$

COMPOSITION DIAPHRAGM - SIZE - 1/2" (DN15) - FULL PORT										
Outlet Pressure		Max Inlet Pressure				Cv @ % DROOP			Range Spring	
		Metal Seated		Composition Seated		10%	20%	30%	psig	(Barg)
psig	(Barg)	psig	(Barg)	psig	(Barg)					
10	(0.7)	185	(12.8)	185	(12.8)	0.71	1.30	1.89	10-50	(0.7-3.4)
15	(1.0)	300	(20.7)	300	(20.7)	0.77	1.39	1.98	10-50	(0.7-3.4)
20	(1.4)	420	(29.0)	420	(29.0)	0.84	1.48	2.08	10-50	(0.7-3.4)
25	(1.7)	535	(36.9)	425	(29.3)	0.90	1.57	2.17	10-50	(0.7-3.4)
35	(2.4)	685	(47.2)	435	(30.0)	1.03	1.74	2.35	10-50	(0.7-3.4)
50	(3.4)	700	(48.3)	450	(31.0)	1.33	2.17	2.82	40-100	(2.8-6.9)
75	(5.2)	740	(51.0)	475	(32.8)	1.58	2.52	3.43	40-100	(2.8-6.9)
100	(6.9)	740	(51.0)	500	(34.5)	2.07	3.35	3.50	80-150	(5.5-10.3)
125	(8.6)	740	(51.0)	525	(36.2)	2.17	3.50	3.50	80-150	(5.5-10.3)
150	(10.3)	740	(51.0)	550	(37.9)	1.98	3.28	3.50	120-190	(8.3-13.1)
175	(12.1)	740	(51.0)	575	(39.7)	2.00	3.39	3.50	120-190	(8.3-13.1)
200	(13.8)	740	(51.0)	600	(41.4)	2.02	3.50	3.50	150-300	(10.3-20.7)
250	(17.2)	740	(51.0)	650	(44.8)	2.05	3.50	3.50	150-300	(10.3-20.7)
300	(20.7)	740	(51.0)	700	(48.3)	2.09	3.50	3.50	150-300	(10.3-20.7)

COMPOSITION DIAPHRAGM - SIZE - 3/4" (DN20) - FULL PORT										
Outlet Pressure		Max Inlet Pressure				Cv @ % DROOP			Range Spring	
		Metal Seated		Composition Seated		10%	20%	30%	psig	(Barg)
psig	(Barg)	psig	(Barg)	psig	(Barg)					
10	(0.7)	145	(10.0)	145	(10.0)	1.16	2.23	2.86	10-40	(0.7-2.8)
15	(1.0)	230	(15.9)	230	(15.9)	1.26	2.34	3.00	10-40	(0.7-2.8)
20	(1.4)	320	(22.1)	320	(22.1)	1.37	2.44	3.15	10-40	(0.7-2.8)
25	(1.7)	410	(28.3)	410	(28.3)	1.47	2.55	3.29	10-40	(0.7-2.8)
35	(2.4)	540	(37.2)	435	(30.0)	1.97	3.15	4.12	30-60	(2.1-4.1)
50	(3.4)	700	(48.3)	450	(31.0)	2.30	2.69	4.85	30-60	(2.1-4.1)
75	(5.2)	740	(51.0)	475	(32.8)	2.83	4.77	5.00	50-90	(3.4-6.2)
100	(6.9)	740	(51.0)	500	(34.5)	3.33	5.00	5.00	70-110	(4.8-7.6)
125	(8.6)	740	(51.0)	525	(36.2)	3.10	5.00	5.00	90-170	(6.2-11.7)
150	(10.3)	740	(51.0)	550	(37.9)	3.33	5.00	5.00	90-170	(6.2-11.7)
175	(12.1)	740	(51.0)	575	(39.7)	2.17	3.54	4.77	140-300	(9.7-20.7)
200	(13.8)	740	(51.0)	600	(41.4)	2.24	3.60	5.00	140-300	(9.7-20.7)
250	(17.2)	740	(51.0)	650	(44.8)	2.37	3.74	5.00	140-300	(9.7-20.7)
300	(20.7)	740	(51.0)	700	(48.3)	2.58	3.87	5.00	140-300	(9.7-20.7)

COMPOSITION DIAPHRAGM - SIZE - 1" (DN25) - FULL PORT										
Outlet Pressure		Max Inlet Pressure				Cv @ % DROOP			Range Spring	
		Metal Seated		Composition Seated		10%	20%	30%	psig	(Barg)
psig	(Barg)	psig	(Barg)	psig	(Barg)					
10	(0.7)	130	(9.0)	130	(9.0)	1.25	2.41	3.61	10-40	(0.7-2.8)
15	(1.0)	205	(14.1)	205	(14.1)	1.40	2.69	3.81	10-40	(0.7-2.8)
20	(1.4)	285	(19.7)	285	(19.7)	1.55	2.96	4.01	10-40	(0.7-2.8)
25	(1.7)	360	(24.8)	360	(24.8)	1.70	3.24	4.21	10-40	(0.7-2.8)
35	(2.4)	485	(33.4)	435	(30.0)	2.49	4.21	5.07	30-60	(2.1-4.1)
50	(3.4)	695	(47.9)	450	(31.0)	2.90	5.00	6.00	30-60	(2.1-4.1)
75	(5.2)	740	(51.0)	475	(32.8)	3.67	6.00	6.00	55-80	(3.8-5.5)
100	(6.9)	740	(51.0)	500	(34.5)	3.85	6.00	6.00	65-130	(4.5-9.0)
125	(8.6)	740	(51.0)	525	(36.2)	3.70	6.00	6.00	100-300	(6.9-20.7)
150	(10.3)	740	(51.0)	550	(37.9)	3.76	6.00	6.00	100-300	(6.9-20.7)
175	(12.1)	740	(51.0)	575	(39.7)	3.83	6.00	6.00	100-300	(6.9-20.7)
200	(13.8)	740	(51.0)	600	(41.4)	3.89	6.00	6.00	100-300	(6.9-20.7)
250	(17.2)	740	(51.0)	650	(44.8)	4.02	6.00	6.00	100-300	(6.9-20.7)
300	(20.7)	740	(51.0)	700	(48.3)	4.15	6.00	6.00	100-300	(6.9-20.7)

METRIC CONVERSION FACTOR: $C_v \div 1.16 = k_v$

TABLE 9 (Continued)
Cv – FLOW CAPACITY

FULL PORT – COMPOSITION DIAPHRAGM

Based on 400 psid (27.6 Bard) max pressure drop limit for composition seat,
and on 650 psid (44.8 Bard) for metal seat.

$(F_L = 0.93)$

COMPOSITION DIAPHRAGM - SIZE - 1-1/4" (DN32) - FULL PORT										
Outlet Pressure		Max Inlet Pressure				Cv @ % DROOP			Range Spring	
		Metal Seated		Composition Seated		10%	20%	30%	psig	(Barg)
psig	(Barg)	psig	(Barg)	psig	(Barg)					
10	(0.7)	105	(7.2)	105	(7.2)	1.83	4.07	6.25	10-40	(0.7-2.8)
15	(1.0)	170	(11.7)	170	(11.7)	2.11	4.55	6.69	10-40	(0.7-2.8)
20	(1.4)	235	(16.2)	235	(16.2)	2.40	5.03	7.13	10-40	(0.7-2.8)
25	(1.7)	300	(20.7)	300	(20.7)	2.68	5.51	7.58	10-40	(0.7-2.8)
35	(2.4)	380	(26.2)	380	(26.2)	4.10	7.70	9.00	30-50	(2.1-3.4)
50	(3.4)	525	(36.2)	450	(31.0)	5.30	8.83	9.00	40-60	(2.7-4.1)
75	(5.2)	670	(46.2)	475	(32.8)	7.70	9.00	9.00	50-90	(3.4-6.2)
100	(6.9)	495	(34.1)	495	(34.1)	8.68	9.00	9.00	70-225	(4.8-15.5)
125	(8.6)	700	(48.3)	525	(36.2)	8.73	9.00	9.00	70-225	(4.8-15.5)
150	(10.3)	740	(51.0)	550	(37.9)	8.79	9.00	9.00	70-225	(4.8-15.5)
175	(12.1)	740	(51.0)	575	(39.7)	8.84	9.00	9.00	70-225	(4.8-15.5)
200	(13.8)	740	(51.0)	600	(41.4)	8.90	9.00	9.00	70-225	(4.8-15.5)
225	(15.5)	740	(51.0)	625	(43.1)	8.95	9.00	9.00	70-225	(4.8-15.5)

COMPOSITION DIAPHRAGM - SIZE - 1-1/2" (DN40) - FULL PORT										
Outlet Pressure		Max Inlet Pressure				Cv @ % DROOP			Range Spring	
		Metal Seated		Composition Seated		10%	20%	30%	psig	(Barg)
psig	(Barg)	psig	(Barg)	psig	(Barg)					
10	(0.7)	110	(7.6)	110	(7.6)	2.37	4.59	6.87	10-40	(0.7-2.8)
15	(1.0)	180	(12.4)	180	(12.4)	2.75	5.20	7.38	10-40	(0.7-2.8)
20	(1.4)	245	(16.9)	245	(16.9)	3.14	5.80	7.90	10-40	(0.7-2.8)
25	(1.7)	315	(21.7)	315	(21.7)	3.52	6.41	8.41	10-40	(0.7-2.8)
35	(2.4)	395	(27.3)	395	(27.3)	4.40	8.80	10.00	30-75	(2.1-5.2)
50	(3.4)	600	(41.4)	450	(31.0)	5.50	9.05	10.55	30-75	(2.1-5.2)
75	(5.2)	740	(51.0)	475	(32.8)	6.35	9.65	10.90	60-100	(4.1-6.9)
100	(6.9)	740	(51.0)	500	(34.5)	7.33	10.25	11.00	80-225	(5.5-15.5)
125	(8.6)	740	(51.0)	525	(36.2)	7.49	10.32	11.00	80-225	(5.5-15.5)
150	(10.3)	740	(51.0)	550	(37.9)	7.65	10.39	11.00	80-225	(5.5-15.5)
175	(12.1)	740	(51.0)	575	(39.7)	7.81	10.46	11.00	80-225	(5.5-15.5)
200	(13.8)	740	(51.0)	600	(41.4)	7.97	10.53	11.00	80-225	(5.5-15.5)
225	(15.5)	740	(51.0)	625	(43.1)	8.13	10.60	11.00	80-225	(5.5-15.5)

COMPOSITION DIAPHRAGM - SIZE - 2" (DN50) - FULL PORT										
Outlet Pressure		Max Inlet Pressure				Cv @ % DROOP			Range Spring	
		Metal Seated		Composition Seated		10%	20%	30%	psig	(Barg)
psig	(Barg)	psig	(Barg)	psig	(Barg)					
10	(0.7)	120	(8.3)	120	(8.3)	3.60	7.27	10.30	10-40	(0.7-2.8)
15	(1.0)	220	(15.2)	220	(15.2)	3.84	7.60	10.83	10-40	(0.7-2.8)
20	(1.4)	315	(21.7)	315	(21.7)	4.08	7.92	11.36	10-40	(0.7-2.8)
25	(1.7)	415	(28.6)	415	(28.6)	4.32	8.25	11.89	10-40	(0.7-2.8)
35	(2.4)	420	(29.0)	420	(29.0)	7.90	11.05	12.80	30-60	(2.1-4.1)
50	(3.4)	690	(47.6)	450	(31.0)	8.80	11.75	13.00	30-60	(2.1-4.1)
75	(5.2)	740	(51.0)	475	(32.8)	7.27	10.63	12.37	50-150	(3.4-10.3)
100	(6.9)	740	(51.0)	500	(34.5)	7.78	10.95	12.70	50-150	(3.4-10.3)
125	(8.6)	740	(51.0)	525	(36.2)	8.29	11.26	12.90	50-150	(3.4-10.3)
150	(10.3)	740	(51.0)	550	(37.9)	8.80	11.58	13.00	50-150	(3.4-10.3)

METRIC CONVERSION FACTOR: $C_v \div 1.16 = k_v$

TABLE 10
Cv – FLOW CAPACITY

OPT -12, 1-STEP REDUCED PORT – COMPOSITION DIAPHRAGM

Based on 400 psid (27.6 Bard) max pressure drop limit for composition seat,
and on 650 psid (44.8 Bard) for metal seat.

$(F_L = 0.93)$

COMPOSITION DIAPHRAGM - SIZE - 1/2" (DN15) - 1-STEP REDUCED PORT										
Outlet Pressure		Max Inlet Pressure				Cv @ % DROOP			Range Spring	
		Metal Seated		Composition Seated		10%	20%	30%	psig	(Barg)
psig	(Barg)	psig	(Barg)	psig	(Barg)					
10	(0.7)	200	(13.8)	220	(15.2)	0.47	1.00	1.55	10-50	(0.7-3.4)
15	(1.0)	335	(23.1)	370	(25.5)	0.53	1.10	1.61	10-50	(0.7-3.4)
20	(1.4)	475	(32.8)	420	(29.0)	0.60	1.18	1.68	10-50	(0.7-3.4)
25	(1.7)	610	(42.1)	425	(29.3)	0.66	1.26	1.74	10-50	(0.7-3.4)
35	(2.4)	685	(47.2)	435	(30.0)	0.78	1.42	1.86	10-50	(0.7-3.4)
50	(3.4)	740	(51.0)	450	(31.0)	1.06	1.79	2.22	40-100	(2.8-6.9)
75	(5.2)	740	(51.0)	475	(32.8)	1.26	2.09	2.36	40-100	(2.8-6.9)
100	(6.9)	740	(51.0)	500	(34.5)	1.67	2.44	2.50	80-150	(5.5-10.3)
125	(8.6)	740	(51.0)	525	(36.2)	1.79	2.50	2.50	80-150	(5.5-10.3)
150	(10.3)	740	(51.0)	550	(37.9)	1.74	2.48	2.50	120-190	(8.3-13.1)
175	(12.1)	740	(51.0)	575	(39.7)	1.81	2.50	2.50	120-190	(8.3-13.1)
200	(13.8)	740	(51.0)	600	(41.4)	1.57	2.37	2.50	150-300	(10.3-20.7)
250	(17.2)	740	(51.0)	650	(44.8)	1.66	2.42	2.50	150-300	(10.3-20.7)
300	(20.7)	740	(51.0)	700	(48.3)	1.75	2.48	2.50	150-300	(10.3-20.7)

COMPOSITION DIAPHRAGM - SIZE - 3/4" (DN20) - 1-STEP REDUCED PORT										
Outlet Pressure		Max Inlet Pressure				Cv @ % DROOP			Range Spring	
		Metal Seated		Composition Seated		10%	20%	30%	psig	(Barg)
psig	(Barg)	psig	(Barg)	psig	(Barg)					
10	(0.7)	175	(12.1)	300	(20.7)	0.71	1.30	1.89	10-40	(0.7-2.8)
15	(1.0)	280	(19.3)	415	(28.6)	0.77	1.39	1.98	10-40	(0.7-2.8)
20	(1.4)	380	(26.2)	420	(29.0)	0.84	1.48	2.08	10-40	(0.7-2.8)
25	(1.7)	480	(33.1)	425	(29.3)	0.90	1.57	2.17	10-40	(0.7-2.8)
35	(2.4)	665	(45.9)	435	(30.0)	1.03	1.74	2.35	30-60	(2.1-4.1)
50	(3.4)	740	(51.0)	450	(31.0)	1.33	2.17	2.82	30-60	(2.1-4.1)
75	(5.2)	740	(51.0)	475	(32.8)	1.58	2.52	3.43	50-90	(3.4-6.2)
100	(6.9)	740	(51.0)	500	(34.5)	2.07	3.35	3.50	70-110	(4.8-7.6)
125	(8.6)	740	(51.0)	525	(36.2)	2.17	3.50	3.50	90-170	(6.2-11.7)
150	(10.3)	740	(51.0)	550	(37.9)	2.12	3.47	3.50	140-300	(9.7-20.7)
175	(12.1)	740	(51.0)	575	(39.7)	2.00	3.39	3.50	140-300	(9.7-20.7)
200	(13.8)	740	(51.0)	600	(41.4)	2.02	3.50	3.50	140-300	(9.7-20.7)
250	(17.2)	740	(51.0)	650	(44.8)	2.05	3.50	3.50	140-300	(9.7-20.7)
300	(20.7)	740	(51.0)	700	(48.3)	2.09	3.50	3.50	140-300	(9.7-20.7)

COMPOSITION DIAPHRAGM - SIZE - 1" (DN25) - 1-STEP REDUCED PORT										
Outlet Pressure		Max Inlet Pressure				Cv @ % DROOP			Range Spring	
		Metal Seated		Composition Seated		10%	20%	30%	psig	(Barg)
psig	(Barg)	psig	(Barg)	psig	(Barg)					
10	(0.7)	170	(11.7)	250	(17.2)	0.86	1.72	2.57	10-40	(0.7-2.8)
15	(1.0)	270	(18.6)	400	(27.6)	0.96	1.93	2.83	10-40	(0.7-2.8)
20	(1.4)	370	(25.5)	420	(29.0)	1.07	2.15	3.09	10-40	(0.7-2.8)
25	(1.7)	475	(32.8)	425	(29.3)	1.17	2.36	3.36	10-40	(0.7-2.8)
35	(2.4)	635	(43.8)	435	(30.0)	1.57	3.50	4.60	30-60	(2.1-4.1)
50	(3.4)	740	(51.0)	450	(31.0)	1.95	4.50	5.46	30-60	(2.1-4.1)
75	(5.2)	740	(51.0)	475	(32.8)	2.85	5.46	5.46	55-80	(3.8-5.5)
100	(6.9)	740	(51.0)	500	(34.5)	2.74	5.38	5.46	65-130	(4.5-9.0)
125	(8.6)	740	(51.0)	525	(36.2)	2.50	5.20	5.46	100-300	(6.9-20.7)
150	(10.3)	740	(51.0)	550	(37.9)	2.58	5.38	5.46	100-300	(6.9-20.7)
175	(12.1)	740	(51.0)	575	(39.7)	2.66	5.46	5.46	100-300	(6.9-20.7)
200	(13.8)	740	(51.0)	600	(41.4)	2.74	5.46	5.46	100-300	(6.9-20.7)
250	(17.2)	740	(51.0)	650	(44.8)	2.91	5.46	5.46	100-300	(6.9-20.7)
300	(20.7)	740	(51.0)	700	(48.3)	3.07	5.46	5.46	100-300	(6.9-20.7)

METRIC CONVERSION FACTOR: $C_v \div 1.16 = k_v$

TABLE 10 (Continued)
C_v – FLOW CAPACITY

OPT -12, 1-STEP REDUCED PORT – COMPOSITION DIAPHRAGM

Based on 400 psid (27.6 Bard) max pressure drop limit for composition seat,
 and on 650 psid (44.8 Bard) for metal seat.

$$(F_L = 0.93)$$

COMPOSITION DIAPHRAGM - SIZE -1-1/2" (DN40) - 1-STEP REDUCED PORT										
Outlet Pressure		Max Inlet Pressure				C _v @ % DROOP			Range Spring	
		Metal Seated		Composition Seated		10%	20%	30%	psig	(Barg)
psig	(Barg)	psig	(Barg)	psig	(Barg)					
10	(0.7)	165	(11.4)	225	(15.5)	1.25	2.41	3.61	10-40	(0.7-2.8)
15	(1.0)	265	(18.3)	365	(25.2)	1.40	2.69	3.81	10-40	(0.7-2.8)
20	(1.4)	360	(24.8)	420	(29.0)	1.55	2.96	4.01	10-40	(0.7-2.8)
25	(1.7)	460	(31.7)	425	(29.3)	1.70	3.24	4.21	10-40	(0.7-2.8)
35	(2.4)	570	(39.3)	435	(30.0)	2.49	4.21	5.07	30-75	(2.1-5.2)
50	(3.4)	700	(48.3)	450	(31.0)	2.90	5.00	6.00	30-75	(2.1-5.2)
75	(5.2)	740	(51.0)	475	(32.8)	3.67	6.00	6.00	60-100	(4.1-6.9)
100	(6.9)	740	(51.0)	500	(34.5)	3.65	6.00	6.00	80-225	(5.5-15.5)
125	(8.6)	740	(51.0)	525	(36.2)	3.70	6.00	6.00	80-225	(5.5-15.5)
150	(10.3)	740	(51.0)	550	(37.9)	3.76	6.00	6.00	80-225	(5.5-15.5)
175	(12.1)	740	(51.0)	575	(39.7)	3.83	6.00	6.00	80-225	(5.5-15.5)
200	(13.8)	740	(51.0)	600	(41.4)	3.89	6.00	6.00	80-225	(5.5-15.5)
225	(15.5)	740	(51.0)	625	(43.1)	3.95	6.00	6.00	80-225	(5.5-15.5)

COMPOSITION DIAPHRAGM - SIZE -2" (DN50) - 1-STEP REDUCED PORT										
Outlet Pressure		Max Inlet Pressure				C _v @ % DROOP			Range Spring	
		Metal Seated		Composition Seated		10%	20%	30%	psig	(Barg)
psig	(Barg)	psig	(Barg)	psig	(Barg)					
10	(0.7)	145	(10.0)	145	(10.0)	2.37	4.59	6.87	10-40	(0.7-2.8)
15	(1.0)	245	(16.9)	245	(16.9)	2.75	5.20	7.38	10-40	(0.7-2.8)
20	(1.4)	340	(23.4)	340	(23.4)	3.14	5.80	7.90	10-40	(0.7-2.8)
25	(1.7)	430	(29.7)	425	(29.3)	3.52	6.41	8.41	10-40	(0.7-2.8)
35	(2.4)	460	(31.7)	435	(30.0)	4.40	8.80	10.00	30-60	(2.1-4.1)
50	(3.4)	690	(47.6)	450	(31.0)	5.50	9.05	10.55	30-60	(2.1-4.1)
75	(5.2)	740	(51.0)	475	(32.8)	6.35	9.65	10.90	50-150	(3.4-10.3)
100	(6.9)	740	(51.0)	500	(34.5)	7.33	10.25	11.00	50-150	(3.4-10.3)
125	(8.6)	740	(51.0)	525	(36.2)	7.49	10.32	11.00	50-150	(3.4-10.3)
150	(10.3)	740	(51.0)	550	(37.9)	7.65	10.39	11.00	50-150	(3.4-10.3)

METRIC CONVERSION FACTOR: $C_v \div 1.16 = k_v$

TABLE 11
Cv – FLOW CAPACITY

FULL PORT – METAL DIAPHRAGM

Based on 400 psid (27.6 Bard) max pressure drop limit for composition seat,
and on 650 psid (44.8 Bard) for metal seat.

$(F_L = 0.93)$

METAL DIAPHRAGM - SIZE - 1/2" (DN15) - FULL PORT										
Outlet Pressure		Max Inlet Pressure				Cv @ % DROOP			Range Spring	
		Metal Seated		Composition Seated		10%	20%	30%	psig	(Barg)
psig	(Barg)	psig	(Barg)	psig	(Barg)					
10	(0.7)	215	(14.8)	215	(14.8)	0.42	0.81	1.18	10-50	(0.7-3.4)
15	(1.0)	335	(23.1)	335	(23.1)	0.47	0.89	1.27	10-50	(0.7-3.4)
20	(1.4)	450	(31.0)	420	(29.0)	0.53	0.98	1.37	10-50	(0.7-3.4)
25	(1.7)	570	(39.3)	425	(29.3)	0.58	1.04	1.45	10-50	(0.7-3.4)
35	(2.4)	685	(47.2)	435	(30.0)	0.67	1.18	1.62	10-50	(0.7-3.4)
50	(3.4)	740	(51.0)	450	(31.0)	0.88	1.52	2.01	40-100	(2.8-6.9)
75	(5.2)	740	(51.0)	475	(32.8)	1.03	1.78	2.34	40-100	(2.8-6.9)
100	(6.9)	740	(51.0)	500	(34.5)	1.59	2.58	3.50	80-150	(5.5-10.3)
125	(8.6)	740	(51.0)	525	(36.2)	1.72	2.69	3.50	80-150	(5.5-10.3)
150	(10.3)	740	(51.0)	550	(37.9)	1.64	2.66	3.40	120-190	(8.3-13.1)
175	(12.1)	740	(51.0)	575	(39.7)	1.72	2.80	3.50	120-190	(8.3-13.1)
200	(13.8)	740	(51.0)	600	(41.4)	1.58	2.64	3.50	150-300	(10.3-20.7)
250	(17.2)	740	(51.0)	650	(44.8)	1.67	2.72	3.50	150-300	(10.3-20.7)
300	(20.7)	740	(51.0)	700	(48.3)	1.77	2.88	3.50	150-300	(10.3-20.7)

METAL DIAPHRAGM - SIZE - 3/4" (DN20) - FULL PORT										
Outlet Pressure		Max Inlet Pressure				Cv @ % DROOP			Range Spring	
		Metal Seated		Composition Seated		10%	20%	30%	psig	(Barg)
psig	(Barg)	psig	(Barg)	psig	(Barg)					
10	(0.7)	160	(11.0)	160	(11.0)	0.70	1.36	2.07	10-40	(0.7-2.8)
15	(1.0)	250	(17.2)	250	(17.2)	0.76	1.50	2.20	10-40	(0.7-2.8)
20	(1.4)	340	(23.4)	340	(23.4)	0.82	1.65	2.34	10-40	(0.7-2.8)
25	(1.7)	425	(29.3)	425	(29.3)	0.88	1.77	2.44	10-40	(0.7-2.8)
35	(2.4)	580	(40.0)	435	(30.0)	1.00	2.01	2.65	30-60	(2.1-4.1)
50	(3.4)	700	(48.3)	450	(31.0)	1.33	2.66	3.47	30-60	(2.1-4.1)
75	(5.2)	740	(51.0)	475	(32.8)	1.93	3.32	4.43	50-90	(3.4-6.2)
100	(6.9)	740	(51.0)	500	(34.5)	2.56	4.18	5.00	70-110	(4.8-7.6)
125	(8.6)	740	(51.0)	525	(36.2)	2.43	4.00	5.00	90-170	(6.2-11.7)
150	(10.3)	740	(51.0)	550	(37.9)	2.57	4.18	5.00	90-170	(6.2-11.7)
175	(12.1)	740	(51.0)	575	(39.7)	1.72	3.07	4.14	140-300	(9.7-20.7)
200	(13.8)	740	(51.0)	600	(41.4)	1.80	3.13	4.20	140-300	(9.7-20.7)
250	(17.2)	740	(51.0)	650	(44.8)	2.00	3.38	4.67	140-300	(9.7-20.7)
300	(20.7)	740	(51.0)	700	(48.3)	2.18	3.63	5.00	140-300	(9.7-20.7)

METAL DIAPHRAGM - SIZE - 1" (DN25) - FULL PORT										
Outlet Pressure		Max Inlet Pressure				Cv @ % DROOP			Range Spring	
		Metal Seated		Composition Seated		10%	20%	30%	psig	(Barg)
psig	(Barg)	psig	(Barg)	psig	(Barg)					
10	(0.7)	145	(10.0)	145	(10.0)	0.78	1.55	2.42	10-40	(0.7-2.8)
15	(1.0)	220	(15.2)	220	(15.2)	0.87	2.10	2.67	10-40	(0.7-2.8)
20	(1.4)	300	(20.7)	300	(20.7)	0.96	1.92	2.93	10-40	(0.7-2.8)
25	(1.7)	375	(25.9)	375	(25.9)	1.04	2.13	3.13	10-40	(0.7-2.8)
35	(2.4)	515	(35.5)	435	(30.0)	1.21	2.54	3.53	30-60	(2.1-4.1)
50	(3.4)	700	(48.3)	450	(31.0)	1.67	3.47	4.62	30-60	(2.1-4.1)
75	(5.2)	740	(51.0)	475	(32.8)	2.25	4.79	6.00	55-80	(3.8-5.5)
100	(6.9)	740	(51.0)	500	(34.5)	3.03	5.20	6.00	65-130	(4.5-9.0)
125	(8.6)	740	(51.0)	525	(36.2)	2.80	4.93	6.00	100-300	(6.9-20.7)
150	(10.3)	740	(51.0)	550	(37.9)	2.88	5.02	6.00	100-300	(6.9-20.7)
175	(12.1)	740	(51.0)	575	(39.7)	2.95	5.11	6.00	100-300	(6.9-20.7)
200	(13.8)	740	(51.0)	600	(41.4)	3.03	5.20	6.00	100-300	(6.9-20.7)
250	(17.2)	740	(51.0)	650	(44.8)	3.18	5.32	6.00	100-300	(6.9-20.7)
300	(20.7)	740	(51.0)	700	(48.3)	3.33	5.45	6.00	100-300	(6.9-20.7)

METRIC CONVERSION FACTOR: $C_v \div 1.16 = k_v$

TABLE 11 (Continued)
Cv – FLOW CAPACITY

FULL PORT – METAL DIAPHRAGM

Based on 400 psid (27.6 Bard) max pressure drop limit for composition seat,
 and on 650 psid (44.8 Bard) for metal seat.

$$(F_L = 0.93)$$

METAL DIAPHRAGM - SIZE -1-1/4" (DN32) - FULL PORT										
Outlet Pressure		Max Inlet Pressure				Cv @ % DROOP			Range Spring	
		Metal Seated		Composition Seated		10%	20%	30%	psig	(Barg)
psig	(Barg)	psig	(Barg)	psig	(Barg)					
10	(0.7)	115	(7.9)	115	(7.9)	1.30	2.80	4.40	10-40	(0.7-2.8)
15	(1.0)	180	(12.4)	180	(12.4)	1.47	3.18	4.87	10-40	(0.7-2.8)
20	(1.4)	240	(16.6)	240	(16.6)	1.64	3.55	5.34	10-40	(0.7-2.8)
25	(1.7)	300	(20.7)	300	(20.7)	1.81	3.93	5.81	10-40	(0.7-2.8)
35	(2.4)	370	(25.5)	370	(25.5)	2.35	6.13	8.30	30-50	(2.1-3.4)
50	(3.4)	500	(34.5)	450	(31.0)	4.55	8.60	9.00	40-60	(2.8-4.1)
75	(5.2)	670	(46.2)	475	(32.8)	5.30	8.92	9.00	50-90	(3.4-6.2)
100	(6.9)	740	(51.0)	495	(34.1)	6.80	9.00	9.00	70-225	(4.8-15.5)
125	(8.6)	740	(51.0)	525	(36.2)	6.90	9.00	9.00	70-225	(4.8-15.5)
150	(10.3)	740	(51.0)	550	(37.9)	6.99	9.00	9.00	70-225	(4.8-15.5)
175	(12.1)	740	(51.0)	575	(39.7)	7.09	9.00	9.00	70-225	(4.8-15.5)
200	(13.8)	740	(51.0)	600	(41.4)	7.19	9.00	9.00	70-225	(4.8-15.5)
225	(15.5)	740	(51.0)	625	(43.1)	7.38	9.00	9.00	70-225	(4.8-15.5)

METAL DIAPHRAGM - SIZE -1-1/2" (DN40) - FULL PORT										
Outlet Pressure		Max Inlet Pressure				Cv @ % DROOP			Range Spring	
		Metal Seated		Composition Seated		10%	20%	30%	psig	(Barg)
psig	(Barg)	psig	(Barg)	psig	(Barg)					
10	(0.7)	115	(7.9)	115	(7.9)	1.75	3.27	4.82	10-40	(0.7-2.8)
15	(1.0)	190	(13.1)	190	(13.1)	2.04	3.79	5.42	10-40	(0.7-2.8)
20	(1.4)	260	(17.9)	260	(17.9)	2.33	4.30	6.01	10-40	(0.7-2.8)
25	(1.7)	330	(22.8)	330	(22.8)	2.62	4.82	6.61	10-40	(0.7-2.8)
35	(2.4)	435	(30.0)	435	(30.0)	3.75	6.53	8.70	30-75	(2.1-5.2)
50	(3.4)	635	(43.8)	450	(31.0)	4.15	7.15	9.10	30-75	(2.8-5.2)
75	(5.2)	740	(51.0)	475	(32.8)	5.30	8.75	10.30	60-100	(4.1-6.9)
100	(6.9)	740	(51.0)	500	(34.5)	6.10	9.40	10.75	80-225	(5.5-15.5)
125	(8.6)	740	(51.0)	525	(36.2)	6.23	9.49	10.78	80-225	(5.5-15.5)
150	(10.3)	740	(51.0)	550	(37.9)	6.37	9.58	10.80	80-225	(5.5-15.5)
175	(12.1)	740	(51.0)	575	(39.7)	6.50	9.68	10.83	80-225	(5.5-15.5)
200	(13.8)	740	(51.0)	600	(41.4)	6.63	9.77	10.85	80-225	(5.5-15.5)
225	(15.5)	740	(51.0)	625	(43.1)	6.90	9.95	10.90	80-225	(5.5-15.5)

METAL DIAPHRAGM - SIZE -2" (DN50) - FULL PORT										
Outlet Pressure		Max Inlet Pressure				Cv @ % DROOP			Range Spring	
		Metal Seated		Composition Seated		10%	20%	30%	psig	(Barg)
psig	(Barg)	psig	(Barg)	psig	(Barg)					
10	(0.7)	165	(11.4)	165	(11.4)	2.10	4.27	6.55	10-40	(0.7-2.8)
15	(1.0)	270	(18.6)	270	(18.6)	2.26	4.58	6.90	10-40	(0.7-2.8)
20	(1.4)	370	(25.5)	370	(25.5)	2.42	4.90	7.25	10-40	(0.7-2.8)
25	(1.7)	470	(32.4)	425	(29.3)	2.59	5.21	7.60	10-40	(0.7-2.8)
35	(2.4)	500	(34.5)	435	(30.0)	5.55	9.60	11.30	30-60	(2.1-4.1)
50	(3.4)	700	(48.3)	450	(31.0)	6.85	10.35	12.00	30-60	(2.1-4.1)
75	(5.2)	740	(51.0)	475	(32.8)	5.87	9.70	11.40	50-150	(3.4-10.3)
100	(6.9)	740	(51.0)	500	(34.5)	6.48	10.03	11.73	50-150	(3.4-10.3)
125	(8.6)	740	(51.0)	525	(36.2)	7.09	10.37	12.07	50-150	(3.4-10.3)
150	(10.3)	740	(51.0)	550	(37.9)	7.70	10.70	12.40	50-150	(3.4-10.3)

METRIC CONVERSION FACTOR: $C_v \div 1.16 = k_v$

TABLE 12
Cv – FLOW CAPACITY

OPT -12, 1-STEP REDUCED PORT – METAL DIAPHRAGM

Based on 400 psid (27.6 Bard) max pressure drop limit for composition seat,
and on 650 psid (44.8 Bard) for metal seat.

$(F_L = 0.93)$

METAL DIAPHRAGM - SIZE - 1/2" (DN15) - 1 -STEP REDUCED PORT										
Outlet Pressure		Max Inlet Pressure				Cv @ % DROOP			Range Spring	
		Metal Seated		Composition Seated		10%	20%	30%	psig	(Barg)
psig	(Barg)	psig	(Barg)	psig	(Barg)					
10	(0.7)	270	(18.6)	300	(20.7)	0.23	0.57	0.87	10-50	(0.7-3.4)
15	(1.0)	405	(27.9)	415	(28.6)	0.27	0.59	0.95	10-50	(0.7-3.4)
20	(1.4)	540	(37.2)	420	(29.0)	0.31	0.61	1.03	10-50	(0.7-3.4)
25	(1.7)	670	(46.2)	425	(29.3)	0.36	0.63	1.12	10-50	(0.7-3.4)
35	(2.4)	685	(47.2)	435	(30.0)	0.44	0.66	1.28	10-50	(0.7-3.4)
50	(3.4)	740	(51.0)	450	(31.0)	0.63	1.21	1.67	40-100	(2.8-6.9)
75	(5.2)	740	(51.0)	475	(32.8)	0.83	1.52	2.03	40-100	(2.8-6.9)
100	(6.9)	740	(51.0)	500	(34.5)	1.24	2.10	2.45	80-150	(5.5-10.3)
125	(8.6)	740	(51.0)	525	(36.2)	1.32	2.18	2.52	80-150	(5.5-10.3)
150	(10.3)	740	(51.0)	550	(37.9)	1.29	2.17	2.52	120-190	(8.3-13.1)
175	(12.1)	740	(51.0)	575	(39.7)	1.36	2.22	2.52	120-190	(8.3-13.1)
200	(13.8)	740	(51.0)	600	(41.4)	1.28	2.13	2.52	150-300	(10.3-20.7)
250	(17.2)	740	(51.0)	650	(44.8)	1.37	2.21	2.52	150-300	(10.3-20.7)
300	(20.7)	740	(51.0)	700	(48.3)	1.45	2.29	2.52	150-300	(10.3-20.7)

METAL DIAPHRAGM - SIZE - 3/4" (DN20) - 1 -STEP REDUCED PORT										
Outlet Pressure		Max Inlet Pressure				Cv @ % DROOP			Range Spring	
		Metal Seated		Composition Seated		10%	20%	30%	psig	(Barg)
psig	(Barg)	psig	(Barg)	psig	(Barg)					
10	(0.7)	190	(13.1)	325	(22.4)	0.42	0.81	1.18	10-40	(0.7-2.8)
15	(1.0)	295	(20.3)	415	(28.6)	0.47	0.89	1.27	10-40	(0.7-2.8)
20	(1.4)	395	(27.2)	420	(29.0)	0.53	0.98	1.37	10-40	(0.7-2.8)
25	(1.7)	500	(34.5)	425	(29.3)	0.58	1.04	1.45	10-40	(0.7-2.8)
35	(2.4)	685	(47.2)	435	(30.0)	0.67	1.18	1.62	30-60	(2.1-4.1)
50	(3.4)	740	(51.0)	450	(31.0)	0.88	1.52	2.01	30-60	(2.1-4.1)
75	(5.2)	740	(51.0)	475	(32.8)	1.03	1.78	2.34	50-90	(3.4-6.2)
100	(6.9)	740	(51.0)	500	(34.5)	1.59	2.58	3.50	70-110	(4.8-7.6)
125	(8.6)	740	(51.0)	525	(36.2)	1.72	2.69	3.50	90-170	(6.2-11.7)
150	(10.3)	740	(51.0)	550	(37.9)	1.40	2.48	3.45	140-300	(9.7-20.7)
175	(12.1)	740	(51.0)	575	(39.7)	1.49	2.56	3.50	140-300	(9.7-20.7)
200	(13.8)	740	(51.0)	600	(41.4)	1.58	2.64	3.50	140-300	(9.7-20.7)
250	(17.2)	740	(51.0)	650	(44.8)	1.67	2.72	3.50	140-300	(9.7-20.7)
300	(20.7)	740	(51.0)	700	(48.3)	1.77	2.88	3.50	140-300	(9.7-20.7)

METAL DIAPHRAGM - SIZE - 1" (DN25) - 1 -STEP REDUCED PORT										
Outlet Pressure		Max Inlet Pressure				Cv @ % DROOP			Range Spring	
		Metal Seated		Composition Seated		10%	20%	30%	psig	(Barg)
psig	(Barg)	psig	(Barg)	psig	(Barg)					
10	(0.7)	190	(13.1)	280	(19.3)	0.51	1.05	1.55	10-40	(0.7-2.8)
15	(1.0)	290	(20.0)	415	(28.6)	0.57	1.17	1.74	10-40	(0.7-2.8)
20	(1.4)	395	(27.2)	420	(29.0)	0.63	1.29	1.93	10-40	(0.7-2.8)
25	(1.7)	495	(34.1)	425	(29.3)	0.68	1.29	1.93	10-40	(0.7-2.8)
35	(2.4)	675	(46.6)	435	(30.0)	0.68	1.40	2.13	30-60	(2.1-4.1)
50	(3.4)	740	(51.0)	450	(31.0)	0.92	1.90	3.10	30-60	(2.1-4.1)
75	(5.2)	740	(51.0)	475	(32.8)	1.13	2.41	4.02	55-80	(3.8-5.5)
100	(6.9)	740	(51.0)	500	(34.5)	1.75	4.08	5.46	65-130	(4.5-9.0)
125	(8.6)	740	(51.0)	525	(36.2)	2.02	4.83	5.46	65-130	(4.5-9.0)
150	(10.3)	740	(51.0)	550	(37.9)	1.88	4.28	5.46	100-300	(6.9-20.7)
175	(12.1)	740	(51.0)	575	(39.7)	1.94	4.39	5.46	100-300	(6.9-20.7)
200	(13.8)	740	(51.0)	600	(41.4)	1.99	4.50	5.46	100-300	(6.9-20.7)
250	(17.2)	740	(51.0)	650	(44.8)	2.04	4.60	5.46	100-300	(6.9-20.7)
300	(20.7)	740	(51.0)	700	(48.3)	2.15	4.82	5.46	100-300	(6.9-20.7)

METRIC CONVERSION FACTOR: $C_v \div 1.16 = k_v$

TABLE 12 (Continued)
Cv – FLOW CAPACITY

OPT -12, 1-STEP REDUCED PORT – METAL DIAPHRAGM

Based on 400 psid (27.6 Bard) max pressure drop limit for composition seat,
and on 650 psid (44.8 Bard) for metal seat.

$$(F_L = 0.93)$$

METAL DIAPHRAGM - SIZE - 1-1/2" (DN40) - 1-STEP REDUCED PORT										
Outlet Pressure		Max Inlet Pressure				Cv @ % DROOP			Range Spring	
		Metal Seated		Composition Seated						
psig	(Barg)	psig	(Barg)	psig	(Barg)	10%	20%	30%	psig	(Barg)
10	(0.7)	185	(12.8)	255	(17.6)	0.78	1.55	2.42	10-40	(0.7-2.8)
15	(1.0)	285	(19.7)	395	(27.2)	0.87	2.10	2.67	10-40	(0.7-2.8)
20	(1.4)	385	(26.6)	420	(29.0)	0.96	1.92	2.93	10-40	(0.7-2.8)
25	(1.7)	385	(26.6)	425	(29.3)	1.04	2.13	3.13	10-40	(0.7-2.8)
35	(2.4)	660	(45.5)	435	(30.0)	1.21	2.54	3.53	30-75	(2.1-5.2)
50	(3.4)	740	(51.0)	450	(31.0)	1.67	3.47	4.62	30-75	(2.1-5.2)
75	(5.2)	740	(51.0)	475	(32.8)	2.25	4.79	6.00	60-100	(4.1-6.9)
100	(6.9)	740	(51.0)	500	(34.5)	2.72	4.84	6.00	80-225	(5.5-15.5)
125	(8.6)	740	(51.0)	525	(36.2)	2.80	4.93	6.00	80-225	(5.5-15.5)
150	(10.3)	740	(51.0)	550	(37.9)	2.88	5.02	6.00	80-225	(5.5-15.5)
175	(12.1)	740	(51.0)	575	(39.7)	2.95	5.11	6.00	80-225	(5.5-15.5)
200	(13.8)	740	(51.0)	600	(41.4)	3.03	5.20	6.00	80-225	(5.5-15.5)
225	(15.5)	740	(51.0)	625	(43.1)	3.10	5.26	6.00	80-225	(5.5-15.5)

METAL DIAPHRAGM - SIZE - 2" (DN50) - 1-STEP REDUCED PORT										
Outlet Pressure		Max Inlet Pressure				Cv @ % DROOP			Range Spring	
		Metal Seated		Composition Seated						
psig	(Barg)	psig	(Barg)	psig	(Barg)	10%	20%	30%	psig	(Barg)
10	(0.7)	165	(11.4)	165	(11.4)	1.75	3.27	4.82	10-40	(0.7-2.8)
15	(1.0)	265	(18.3)	265	(18.3)	2.04	3.79	5.42	10-40	(0.7-2.8)
20	(1.4)	365	(25.2)	365	(25.2)	2.33	4.30	6.01	10-40	(0.7-2.8)
25	(1.7)	460	(31.7)	425	(29.3)	2.62	4.82	6.61	10-40	(0.7-2.8)
35	(2.4)	530	(36.6)	435	(30.0)	3.75	6.53	8.70	30-60	(2.1-4.1)
50	(3.4)	700	(48.3)	450	(31.0)	4.15	7.15	9.10	30-60	(2.1-4.1)
75	(5.2)	740	(51.0)	475	(32.8)	5.30	8.75	10.30	50-150	(3.4-10.3)
100	(6.9)	740	(51.0)	500	(34.5)	6.10	9.40	10.75	50-150	(3.4-10.3)
125	(8.6)	740	(51.0)	525	(36.2)	6.23	9.49	10.78	50-150	(3.4-10.3)
150	(10.3)	740	(51.0)	550	(37.9)	6.37	9.58	10.80	50-150	(3.4-10.3)

METRIC CONVERSION FACTOR: $C_v \div 1.16 = k_v$

**TABLE 16
CONSOLIDATED PRESSURE vs. TEMPERATURE MATERIALS OPERATING LIMITS,
INCLUDING TRIM AND OPTION LIMITS**

Materials Body/Sprg. Chamber/Cyl	End Conn. Option No.	Trim Design. No.	Inlet Pressure		Outlet Pressure ¹		Inlet & Outlet Temperature Rg		Limiting Portion		
			psig	(Barg)	psig	(Barg)	°F	(°C)			
DI / DI / BRZ BRZ / DI / BRZ BRZ / BRZ / BRZ ³	Std. - NPT Opt-31, Opt-45, Opt-46G	B2, B3	400	(27.6)	300	(20.7)	-20 to +150	(-29 to +66)	BRZ, Mech. Internals		
			390	(26.9)	300	(20.7)	+200	(+93)	BRZ, BC		
		BB	400	(27.6)	300	(20.7)	-20 to +150	(-29 to +66)	BRZ, Mech. Internals		
			400	(27.6)	300	(20.7)	+250	(+121)	BRZ, NBR		
		B1	400	(27.6)	300	(20.7)	-20 to +150	(-29 to +66)	BRZ, Mech. Internals		
			385	(26.6)	300	(20.7)	+200	(+94)	BRZ		
			365	(25.2)	300	(20.7)	+250	(+121)			
			335	(23.1)	300	(20.7)	+300	(+149)			
			300	(20.7)	300	(20.7)	+350	(+177)			
		250	(17.2)	250	(17.2)	+400	(+205)	BRZ, V-TFE			
		B5	400	(27.6)	300	(20.7)	-20 to +150	(-29 to +66)	BRZ, Mech. Internals, Phos. Bronze		
			385	(26.6)	300	(20.7)	+200	(+94)	BC		
DI / DI / SST CS / DI / SST SST / DI / SST	Std. - NPT Opt-31, Opt-32, Opt-45	S2N, S3, S3N, S40	740	(51.0)	300	(20.7)	-20 to +200	(-29 to +93)	Mech. Internals		
			740	(51.0)	300	(20.7)	-20 to +250	(-29 to +121)	NBR		
		SB	740	(51.0)	300	(20.7)	-20 to +250	(-29 to +121)	Mech. Internals		
			300	(20.7)	+268	(+131)	DI, Mech. Internals				
			300	(20.7)	+275	(+135)	DI				
			300	(20.7)	+300	(+149)	DI, EPDM/EPR				
		S0, S1, S2, S5, S9, S36	300	(20.7)	-20 to +250	(-29 to +121)	Mech. Internals				
			300	(20.7)	+268	(+131)	DI, Mech. Internals				
			300	(20.7)	+275	(+135)	DI				
			300	(20.7)	+300	(+149)					
			300	(20.7)	+350	(+177)					
		295	(20.3)	+400	(+205)	DI, V-TFE, FKM					
		Std-NPT Opt-31, Opt-32 Opt-46G	S1, S2	740	(51.0)	270	(18.6)	-20 to +425	(-29 to +219)	DI, Std. Gasket	
		CS / CS / SST SST / CS / SST SST / SST / SST	Std. - NPT, Opt-31, Opt-32, Opt-45	S2N, S3, S3N, S40	740	(51.0)	400	(27.6)	-20 to +200	(-29 to +93)	BC, Mech. Internals
					740	(51.0)	400	(27.6)	-20 to +250	(-29 to +121)	NBR
S6	740			(51.0)	400	(27.6)	-20 to +300	(-29 to +149)	EPDM/EPR, Mech. Internals		
S0, S5, S9, S36	740			(51.0)	400	(27.6)	-20 to +400	(-29 to +205)	V-TFE, FKM, Mech. Internals		
Std. - NPT, Opt-31, Opt-32,	S1, S2		740	(51.0)	400	(27.6)	-20 to +450	(-29 to +232)	Mech. Internals, Std. Gaskets		
Std. - NPT, Opt-31, Opt-46G (Req'd)	S1, S2	740	(51.0)	400	(27.6)	-20 to +600	(-29 to +315)	Mech. Internals, Carbon Graphite Gasket			
CS / DI / SST CS / CS / SST	Opt-30, 150# Flg., Opt-45	S2N, S3, S3N, S40	285	(19.7)	285	(19.7)	-20 to +100	(-29 to +38)	150# Flg.		
			265	(18.3)	265	(18.3)	+200	(+93)	150# Flg., BC		
		SB	285	(19.7)	285	(19.7)	-20 to +100	(-29 to +38)	150# Flg.		
			245	(16.9)	265	(18.3)	+250	(+121)	150# Flg., NBR		
		S6, S7	285	(19.7)	285	(19.7)	-20 to +100	(-29 to +38)	150# Flg.		
			260	(17.9)	260	(17.9)	+200	(+94)	150# Flg., EPDM/EPR		
			230	(15.9)	230	(15.9)	+300	(+149)			
		S0, S5, S9, S36	285	(19.7)	285	(19.7)	-20 to +100	(-29 to +38)	150# Flg.		
			260	(17.9)	260	(17.9)	+200	(+94)			
			230	(15.9)	230	(15.9)	+300	(+149)	V-TFE, FKM, 150# Flg.		
			200	(13.8)	200	(13.8)	+400	(+205)			
		S1, S2	285	(19.7)	285	(19.7)	-20 to +100	(-29 to +38)	150# Flg.		
			260	(17.9)	260	(17.9)	+200	(+94)			
			230	(15.9)	230	(15.9)	+300	(+149)	TFE Gasket, 150# Flg.		
			200	(13.8)	200	(13.8)	+400	(+205)			
OPT-30, 150# FLG., Opt-46G	S1, S2	185	(12.8)	185	(12.8)	-20 to +450	(-29 to +232)	Std. Gasket, 150# Flg., DI			
CS / CS / SST	Opt-30, 150# Flg., & Opt-46G (Req'd)	S1, S2	170	(11.7)	170	(11.7)	-20 to +500	(-29 to +260)	150# Flg.		
			140	(9.7)	140	(9.7)	+600	(315)	Carbon Graphite Gasket, 150# Flg., Mech. Internals		

1 Indicated outlet pressure limits are those to contain overpressure conditions; such overpressure may cause diaphragm damage. It is recommended that pressure safety devices – safety relief valve or rupture disc – have their setpoint relief pressures at 110% of the UVRS (UVRS = “Upper Value of Range Spring”). Example: For a 90–170 psig (6.2–11.7 Barg) range spring, the safety device should be set to relieve at 110% x 170 psig = 187 psig (12.9 Barg). See NOTE 2 below for 300 psig (20.7 barg) outlet pressure limit with Ductile Iron Spring Chamber.

2 Outlet Pressure Limit for CS/DI/SST and SST/DI/SST is 300psig (20.7 barg).
Outlet Pressure Limit for CS/CS/SST and SST/SST/SST is 400psig (27.6 barg).

3 Outlet Pressure Limit for BRZ/BRZ/BRZ is equal to inlet pressure limit.

4 Outlet Pressure Limit for S5 & S7 Trim (FKM) is 300 psig (20.7 barg)

TABLE 16 (Continued)

Materials Body/Sprg. Chamber/Cyl	End Conn. Option No.	Trim Design. No.	Inlet Pressure		Outlet Pressure ¹		Inlet & Outlet Temperature Rg.		Limiting Portion	
			psig	(Barg)	psig	(Barg)	°F	(°C)		
SST / DI / SST SST / CS / SST SST / SST / SST	Opt-30 150# Flg., Opt-45	S2N, S3, S3N, S40	275	(19.0)	275	(19.0)	-20 to +100	(-29 to +38)	150# Flg.	
			245	(16.9)	245	(16.9)	+200	(+93)	150# Flg., BC	
		SB	275	(19.0)	275	(19.0)	-20 to +100	(-29 to +38)	150# Flg.	
			225	(15.5)	245	(16.9)	+250	(+121)	150# Flg., NBR	
		S6, S7	275	(19.0)	275	(19.0)	-20 to +100	(-29 to +38)	150# Flg.	
			240	(16.6)	240	(16.6)	+200	(+94)	150# Flg., EPDM/EPR	
		215	(14.8)	215	(14.8)	+300	(+149)			
		S0, S5, S9, S36	275	(19.0)	275	(19.0)	-20 to +100	(-29 to +38)	150# Flg.	
			240	(16.6)	240	(16.6)	+200	(+94)		
			215	(14.8)	215	(14.8)	+300	(+149)		
		S1, S2	195	(13.4)	195	(13.4)	+400	(+205)	V-TFE, FKM, 150# Flg.	
			275	(19.0)	275	(19.0)	-20 to +100	(-29 to +38)	150# Flg.	
			240	(16.6)	240	(16.6)	+200	(+94)		
			215	(14.8)	215	(14.8)	+300	(+149)		
		**	S1, S2	195	(13.4)	195	(13.4)	+400	(+205)	TFE Gasket, 150# Flg.
180	(12.4)			180	(12.4)	-20 to +450	(-29 to +233)	Std. Gasket, 150# Flg., DI		
SST / CS / SST SST / SST / SST	Opt-30 150# Flg. & Opt-46G (Req'd)	S1, S2	170	(11.7)	170	(11.7)	-20 to +500	(-29 to +260)	150# Flg.	
			140	(9.7)	140	(9.7)	+600	(+315)	150# Flg., Carbon Graphite Gskt., Mech. Internals	
CS / DI / SST ² CS / CS / SST ²	Opt-30 300# Flg., Opt-45	S2N, S3, S3N, S40	740	(51.0)	400	(27.6)	-20 to +100	(-29 to +38)	300# Flg., Mech. Internals	
			685	(47.2)	400	(27.6)	+200	(+93)	300# Flg., Mech. Internals, BC	
		SB	740	(51.0)	400	(27.6)	-20 to +100	(-29 to +38)	300# Flg., Mech. Internals	
			668	(46)	400	(27.6)	+250	(+121)	300# Flg., Mech. Internals, NBR	
		S6, S7	740	(51.0)	400 ⁴	(27.6) ⁴	-20 to +100	(-29 to +38)	300# Flg., Mech. Internals	
			675	(46.6)	400 ⁴	(27.6) ⁴	+200	(+94)	300# Flg., Mech. Internals, EPDM/ EPR	
			655	(45.2)	400 ⁴	(27.6) ⁴	+300	(+149)		
		S0, S5, S9, S36	635	(43.8)	400 ⁴	(27.6) ⁴	+400	(+205)	300# Flg., Mech. Internals, V-TFE, FKM	
			740	(51.0)	400 ⁴	(27.6) ⁴	-20 to +100	(-29 to +38)	300# Flg., Mech. Internals	
			675	(46.6)	400 ⁴	(27.6) ⁴	+200	(+94)		
		S1, S2	655	(45.2)	400 ⁴	(27.6) ⁴	+300	(+149)	300# Flg., Mech. Internals, Carbon graphite Gasket	
			635	(43.8)	400 ⁴	(27.6) ⁴	+400	(+205)		
			615	(42.4)	400	(27.6)	-20 to +450	(-29 to +232)	300# Flg., Mech. Int., TFE Gskt.	
		Opt-30 300# Flg., Opt- 46G	S1, S2	615	(42.4)	400	(27.6)	-20 to +450	(-29 to +232)	300# Flg., Mech. Internals, Std. Gaskets, CI
				600	(41.4)	400	(27.6)	-20 to +500	(-29 to +260)	300# Flg., Mech. Internals, Carbon graphite Gasket
550	(37.9)	400	(27.6)	+600	(+315)					
SST / DI / SST ² SST / CS / SST SST / SST / SST	Opt-30 300# Flg., Opt-45	S2N, S3, S3N, S40	720	(49.7)	400	(27.6)	-20 to +100	(-29 to +38)	300# Flg., Mech. Internals	
			640	(44.1)	400	(27.6)	+200	(+93)	300# Flg., Mech. Internals, BC	
		SB	720	(49.7)	400	(27.6)	-20 to +100	(-29 to +38)	300# Flg., Mech. Internals	
			590	(40.7)	400	(27.6)	+250	(+121)	300# Flg., Mech. Internals, NBR	
		S6, S7	720	(49.7)	400 ⁴	(27.6) ⁴	-20 to +100	(-29 to +38)	300# Flg., Mech. Internals	
			620	(42.8)	400 ⁴	(27.6) ⁴	+200	(+94)	300# Flg., Mech. Internals, EPDM/ EPR	
			560	(38.6)	400 ⁴	(27.6) ⁴	+300	(+149)		
		S0, S5, S9, S36	720	(49.7)	400 ⁴	(27.6) ⁴	-20 to +100	(-29 to +38)	300# Flg., Mech. Internals	
			620	(42.8)	400 ⁴	(27.6) ⁴	+200	(+94)	300# Flg., Mech. Internals, V-TFE, FKM	
			560	(38.6)	400 ⁴	(27.6) ⁴	+300	(+149)		
		S1, S2	515	(35.5)	400 ⁴	(27.6) ⁴	+400	(+205)	300# Flg., Mech. Internals, Carbon graphite Gasket	
			720	(49.7)	400	(27.6)	-20 to +100	(-29 to +38)	300# Flg., Mech. Internals	
			620	(42.8)	400	(27.6)	+200	(+94)		
		Opt-30, 300# Flg., Opt-46G	S1, S2	560	(38.6)	400	(27.6)	+300	(+149)	300# Flg., Mech. Int., TFE Gskt.
				515	(35.5)	400	(27.6)	+400	(+205)	
495	(34.1)			400	(27.6)	-20 to +450	(-29 to +232)	300# Flg., Mech. Internals, Std. Gaskets, CI		
SST / CS / SST	Opt-300, 300# Flg. & Opt-46G (Req'd)	S1, S2	480	(33.1)	400	(27.6)	-20 to +500	(-29 to +260)	300# Flg., Mech. Internals	
SST / SST / SST			450	(31.0)	400	(27.6)	+600	(+315)	300# Flg., Mech. Internals Carbon graphite Gasket	
SST / SST / SST	Opt-37	S6	250	(17.2)	100	(6.9)	-20 to +100	(-29 to +38)	Diaphragm Flg. Bolting	
SST / SST / SST	Opt-37S	S1	100	(6.9)	100	(6.9)	-20 to +350	(-29 to +177)	Diaphragm Flg. Bolting	

** Opt-30 150# Flg., Opt-46G
1,2,3 & 4 See Previous Page

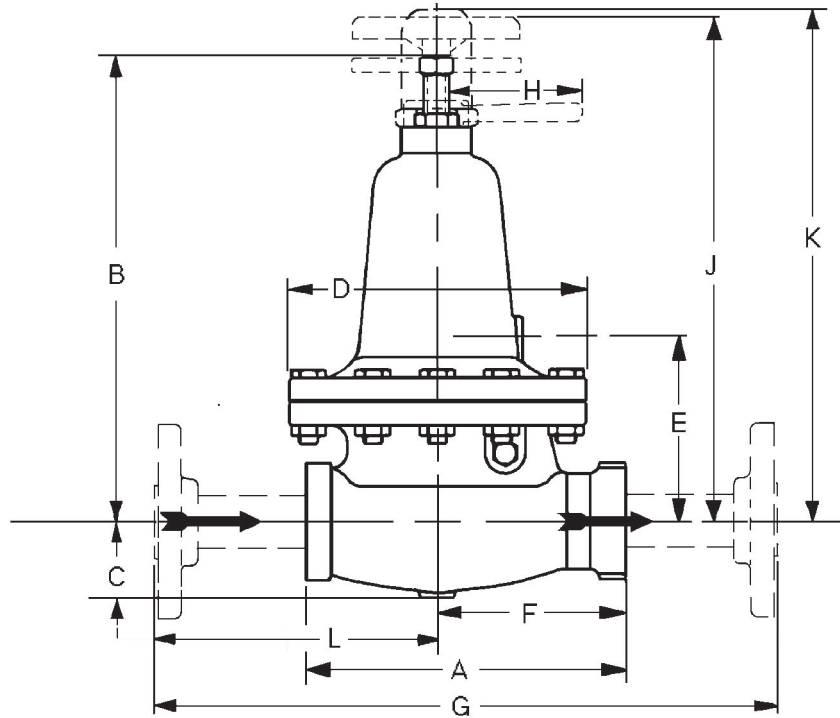

Regulator Size (Inch)	DIMENSIONS – ENGLISH (inch)													Approx. Weight - lbs.	
	A	B	C	D	E	F	G ¹	G ²	G ³	H	J	K	L ⁴	wo/ Flanges	w/ Flanges
1/2"	5.94	10.00	1.62	5.62	3.75	3.94	10.75	11.00	13.94	3.13	11.19	11.62	5.38	18	25
3/4"	7.12	11.25	1.75	6.56	3.81	4.00	11.88	12.25	15.12	3.13	12.25	12.81	5.62	28	35
1"	7.94	11.75	2.12	7.38	4.38	4.69	13.62	14.00	15.94	3.13	12.81	13.44	6.75	37	46
1-1/4"	8.50	12.25	2.38	8.00	4.50	5.06	NA	NA	16.50	4.31	13.94	14.19	NA	48	N/A
1-1/2"	9.75	15.75	2.50	9.12	6.19	5.75	15.88	16.19	17.75	4.31	16.50	17.00	7.31	77	93
2"	11.25	16.00	2.88	11.25	7.06	6.62	19.31	19.62	19.22	4.31	16.88	17.38	9.81	109	131
Regulator Size (DN)	DIMENSIONS – METRIC (mm)													Approx. Weight - kg.	
	A	B	C	D	E	F	G ¹	G ²	G ³	H	J	K	L ⁴	wo/ Flanges	w/ Flanges
(15)	151	254	41	143	95	100	273	279	354	79	284	295	137	8	11
(20)	181	286	44	167	97	102	302	311	384	79	311	325	143	13	16
(25)	202	298	54	187	111	119	346	356	405	79	325	341	171	17	21
(32)	216	311	60	203	114	129	NA	NA	419	110	354	360	NA	22	N/A
(40)	248	400	64	232	157	146	403	411	451	110	419	432	186	35	42
(50)	286	406	73	286	179	168	490	498	488	110	429	441	249	49	59
¹ 150# Flange - Also available with Opt-34, special 14" (356mm) face to face dimension - sizes 1/2" - 1" & 1-1/2" only. ² 300# Flange - Also available with Opt-34, special 14" (356mm) face to face dimension - sizes 1/2" - 1" & 1-1/2" only. ³ P.E. Pipe Nipples. ⁴ "L" dimension for 1-1/2" Size with Opt-34 is 6.13" (156mm).															

The contents of this publication are presented for informational purposes only, and while every effort has been made to ensure their accuracy, they are not to be construed as warranties or guarantees, express or implied, regarding the products or services described herein or their use or applicability. We reserve the right to modify or improve the designs or specifications of such product at any time without notice. Cashco, Inc. does not assume responsibility for the selection, use or maintenance of any product. Responsibility for proper selection, use and maintenance of any Cashco, Inc. product remains solely with the purchaser.

**OPT -37/-37S PRODUCT CODER
FOR THE FOOD AND PHARMACEUTICAL INDUSTRY**

An "X" in POS 12 followed by a 5-digit control number overrides remaining selections.

B **K** POS 3 — **A** POS 6 & 7 **7** — POS 10 POS 11 POS 12 **0** **0** **0** **0** **0** **A**

POSITION 3 - SIZE & SERVICE			
Size		Service	
in	(DN)	Gaseous	Liquid
		CODE	CODE
1/2"	(15)	4	J
3/4"	(20)	5	K
1"	(25)	6	L
1-1/2"	(40)	8	N
2"	(50)	9	P

POSITION 6 & 7 - TRIM DESIGNATION NUMBERS	
Stainless Steel Trim	
Desig.	CODE
S1	S1
S6	S6

POSITION 10 - END CONNECTIONS	
Description	CODE
NPT - Screwed	1
-30 Opt. - 150 LB RF Flgs	6

POSITION 11 - RANGE SPRINGS							
Size	psig (Barg)	(Barg)	CODE	SIZE	psig	(Barg)	CODE
1/2" (DN15)	10-50	(.69-3.4)	3	1-1/2" (DN40)	10-50	(.69-3.4)	3
	40-80	(2.8-5.5)	B		40-80	(2.8-5.5)	B
3/4" (DN20)	10-40	(.69-2.8)	2	2" (DN50)	10-30	(.69-2.1)	1
	30-60	(2.1-4.1)	6		25-45	(1.7-3.1)	5
	50-80	(3.4-5.5)	C		35-80	(2.4-5.5)	9
1" (DN25)	10-30	(.69-2.1)	1				
	25-45	(1.7-3.1)	5				
	35-50	(2.4-3.4)	8				
	40-80	(2.8-5.5)	B				

POSITION 12 - TRIM OPTIONS		
Description	Option	CODE
No Option	—	0
For Special Construction Contact Cashco for Special Product Code.	SPQ	X

*** For information on ATEX see pages 13 & 14 on the IOM.**

MODEL 1000 HP Basic PRODUCT CODER 02/07/20

An "X" in POS 12 followed by a 5-digit control number overrides remaining selections.

B POS 2 POS 3 — POS 5 POS 6 & 7 **7** — POS 10 POS 11 POS 12 POS 13 POS 14 POS 15 POS 16 **0** **A**

POSITION 2 - GASKETS * & SERVICE		
Gaskets - Service	Options	CODE
Standard : Graphite / NBR/ - Non-Oxygen	--	B
TFE /- Primarily for Oxygen	-45	D
Carbon-Graphite - High Temp.	-46G **	G

* Refer to Tech Bulletin for temperature limits.
Gasket not required when selecting Composition Diaphragm
** Only Available with CS or SST Body & Spring Chamber and S1 or S2 Trim.

POSITION 3 - SIZE & SERVICE					
Size		Service			
		Gaseous	Liquid	Viscous (-27 Opt) *	
In	DN	CODE	CODE	CODE	
1/2	(15)	4	J	R	
3/4	(20)	5	K	S	
1	(25)	6	L	T	
1-1/4	(32)	7	M	U	
1-1/2	(40)	8	N	V	
2	(50)	9	P	W	

* Metal Seated B1,S0,S1,S2,S2N,S5 or S40Trim Only.

POSITION 5 - BODY & SPRG CHAMBER MATERIALS			
Body/Sp. Ch.	CODE	Body/Sp. Ch.	CODE
DI/DI	1	CS/CS (WCC/WCB)	5
BRZ/DI *	2	SST/DI *	7
BRZ/BRZ *	3	SST/CS *	9
CS/DI	4	SST/SST *	A

* Note: SST or BRZ Bodies Not Avail. in 1-1/4" (DN32)

POSITION 6 & 7 - TRIM DESIGNATION NUMBERS			
Brass Trim **		Stainless Steel Trim	
Desig.	CODE	Desig.	CODE
B1	B1	S0 *	S0
B2	B2	S1	S1
B3	B3	S2	S2
B5	B5	S2N	SN
BB	BB	S3	S3
BK	BK	S3N	SC
		S5	S5
		S6 *	S6
		S7 *	S7
		S9 *	S9
		S36	36
		S40	40
		S40V	4V
		SB	SB

* Not available for 1-1/4" (DN32) size
** Brass Trims not available with nipple & flange end connections.

POSITION 10 - END CONNECTIONS	
Description	CODE
NPT - Screwed	1
-30 Opt. - 150 LB RF Flgs. * ** (Std)	6
-30 Opt. - 300 LB RF Flgs. * ** (Std)	7
-31 Opt.- BSPT Tapered Thread	B
-31P Opt.- BSPP Parallel Thread	P
-32 Opt. - SCH. 80 PE Ext. Nipples *	E
-34 Opt. - 150 LB RF Flgs. 14" F to F Dimension (Sizes 1/2 -1" & 1-1/2" only) *	V
-34 Opt. - 300 LB RF Flgs. 14" F to F Dimension (Sizes 1/2 -1" & 1-1/2" only)*	W

*Nipples & flanges of same material as body. CS or SST bodies. Use SST trim only.
** Not Available in 1-1/4" (DN32)

POSITION 11 - RANGE SPRINGS					
Size	psig	CODE	Size	psig	CODE
1/2" (DN15)	10-50	1	1-1/4" (DN32)	10-40	2
	40-100	4		30-50	5
	80-150	7		40-60	N
	120-190	B		50-90	8
	150-300 *	F		70-225	L
3/4" (DN20)	10-40	2	1-1/2" (DN40)	10-40	2
	30-60	3		30-75	6
	50-90	8		60-100	A
	70-110	C		80-225	M
	90-170	G		10-40	2
	140-300 *	J	2" (DN50)	30-60	3
1" (DN25)	10-40	2		50-150	E
	30-60	3			
	50-70	9			
	55-80	D			
	65-130	H			
	100-300 *	K			

* With CS 150# Flange Connection max set point up to 285 psig.
With SST 150# Flange Connection max set point up to 275 psig.

POSITION 12 - TRIM VARIATIONS			W/ -17 OPTION	
Description	Option	CODE	Option	CODE
No Special Trim Variation	--	0	--	--
Reduced Orifice (One-Step) Not Available on 1-1/4"(DN32)	-12	A	-12+17	1
Integral Seat Surface (Not available with B1 Trim or NACE)	-14	C	-14+17	3
Stellited Seat Surface Integral Seat - S1 Trim Only	-15 *	D	-15+17 *	4
Reduced Orifice & Integral Seat See above for limitations	-12+14	E	-12+14+17	5
Reduced Orifice & Stellited Seat See above for limitations	-12+15 *	F	-12+15+17 *	6
Piston Spring Not Available on 2" (DN50)**	-17	H	--	--
For Special Construction Contact Cashco for Special Product Code.	SPQ		X	

* Includes Opt-14 Integral Seat.
** Standard with B5 Trim. Do Not Code

POSITION 13 - FEATURE OPTIONS		
	Option	CODE
No Option	-	0
DI Closing Cap for DI or CS Spring Chambers.	-1	1
Handwheel & Locking Lever - 1/2"-1"(DN15 - DN25).	-3	3
T-Bar & Locking Lever - 1 1/4"-2" (DN32 - DN50).	-3	4

POSITION 14 - SPRING CHAMBER OPTIONS		
	Option	CODE
No Option	-	0
1/4" (DN8) NPT Vent Tap.	-25	E
Plastic Rain-proof Bug Vent (includes Opt-25).	-25P	P
SST Rain-proof Bug Vent (includes Opt-25).	-25S	H

POSITION 15 - BODY OPTIONS		
	Option	CODE
No Option	-	0
1/4" (DN8) NPT Drain Hole/Press. Tap.	-26	F
1/8" (DN6) NPT Taps -one at inlet, one at outlet, for Opt-34	-87	V

POSITION 16 - CERTIFICATE OPTIONS		
	Option	CODE
No Option	-	0
NACE Const.: CS/CS/XX, All Sizes Except DN32 Per MR0175, S3, S3N, S40, S40V Trim.	-40	J
NACE Const.:SST/CS/XX, SST/SST/XX All Sizes Except DN32 Per MR0175, S3, S3N, S40, S40V Trim.	-40SST	K
Special Cleaning: Per Cashco Spec #S-1134. W/ properly selected mat'ls. Suitable for Oxygen Service. BRZ or SST body material.	-55	M
Special Cleaning: Per Cashco Spec #S-1542.	-56	N

*** For information on ATEX see pages 13 & 14 on the IOM.**